



RAZBAM POCKET GUIDE

NAVY MODEL

AV-8B

163853 AND UP

AIRCRAFT

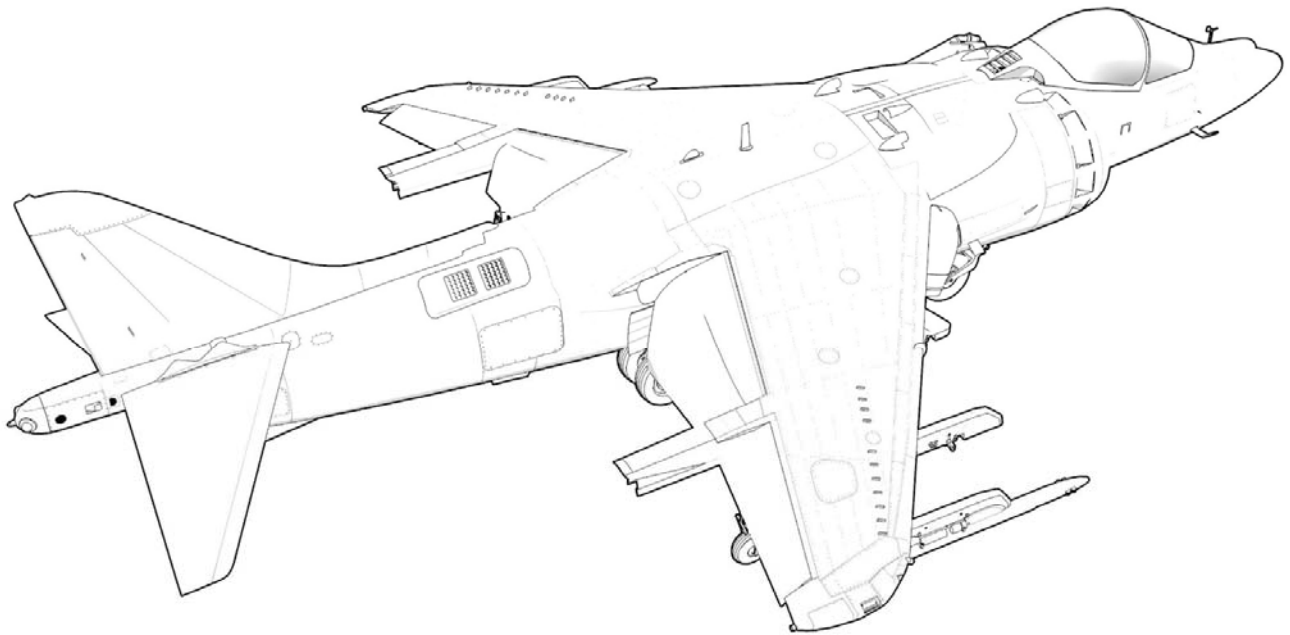

AV-8B
NIGHT ATTACK
V/STOL

DISTRIBUTION STATEMENT — Distribution authorized by Razbam Simulations for official use for the DCS AV-8B Night Attack V/STOL Module.

DCS
S E R I E S

Table of Contents

AIRCRAFT DESCRIPTION	1
COCKPIT	1
Main Instruments Panel.....	1
Left Instruments Panel.....	1
Right Instruments Panel.....	2
Rear Panel Left.....	3
Rear Panel Right.....	4
Throttle Quadrant.....	5
Control Stick.....	7
AIRCRAFT SYSTEMS.....	9
NORMAL PROCEDURES AND CHECKLISTS.....	10
Engine Start.....	10
After Entering Cockpit.....	10
Pre-Start.....	11
Starting Engine.....	12
Before Taxiing.....	12
Taxiing.....	13
Takeoff.....	14
Takeoff Checklist.....	14
Jetborne/Semi-jetborne Takeoffs.....	16
Vertical Takeoff (VTO).....	16
Rolling Vertical Takeoff (RVTO).....	16
Short Takeoff (STO).....	17
Accelerating Transition (AT).....	18
Conventional Takeoff (CTO).....	18
After Takeoff.....	19
Landing.....	19
Landing Checklist.....	19
Decelerating Transition to a Hover.....	20
Vertical Landing (VL).....	21
Decelerating Transition to a Rolling Vertical Landing.....	21
Slow Landing (SL).....	22
Conventional Landing (CL).....	23
After Landing.....	24
Air Refueling.....	25
Before Plug-in checklist.....	25

Refueling	25
AIRCRAFT LIMITATIONS	27
Engine Limits	27
Notes	27
Engine Airstart Envelope.....	27
Notes	28
Airspeed Limitations	28
AOA Limitations	29
Prohibited Maneuvers	29
Prohibited Maneuvers (SAAHS OFF)	30
Weight Limitations.....	30
Acceleration Limitations	30
Crosswinds Limitations	31
Takeoffs.....	31
Landings	31
Systems Limitations	31
All Weather Landing System (ALWS)	31
Automatic Flight Controls (AFC).....	31
Canopy	32
Nozzle/Flap Limitations.....	32
WARNING/CAUTION/ADVISORY LIGHTS AND TONES	33
Master Warning Lights.....	33
Master Caution Lights	33
Caution/Advisory Lights	33
Caution Lights.....	33
Advisory Lights	34
Threat Warning Lights.....	35
Voice Warnings	35
MASTER OPERATIONAL MODES.....	36
NAV	36
VSTOL	36
A/G	36
A/A	37
THE HEAD-UP DISPLAY (HUD)	38
HUD CONTROL PANEL.....	38
HUD BASIC SYMBOLOGY	39
NAV	39

VSTOL	40
ATTACK (A/A and A/G)	41
THE UPFRONT CONTROL (UFC) & OPTION DISPLAY UNIT (ODU)	42
Special Input Keys	43
UFC MODES & FUNCTIONS	43
THE MULTI-PURPOSE COLOR DISPLAYS (MPCD).....	45
Main Menu Options	45
FLIGHT INSTRUMENTS	47
NAVIGATION	49
The Inertial Navigation System (INS)	49
INS Controls and Indicators.....	49
The TACAN (Tactical Air Navigation) System	50
TACAN Controls and Indicators.....	50
The All Weather Landing System (AWLS)	51
AWLS Channels.	51
AWLS Controls and Indicators.....	52
The Electronic Horizontal Situation Display (EHSD).....	53
Flight Plan.....	54
Steering Modes	55
Waypoint.....	55
TACAN	55
AWLS	55
COMMUNICATIONS	56
V/UHF Radios	56
Operating Modes	56
V/UHF Controls and Indicators	57
Emission Control	58
EMCON Controls and Indicators	58
SENSOR MANAGEMENT.....	59
Sensor Select Switch (SSS)	59
Target Designator Control (TDC).....	59
Internal Sensors	60
INS	60
Angle Rate Bombing System (ARBS)	60
FLIR.....	65
External Sensors.....	67
Litening II Pod (TPOD)	67

Maverick (IR & CCD)	67
WEAPONS SYSTEMS	68
Weapons Management	68
Hands on Throttle and Stick (HOTAS)	68
Throttle controls	68
Control Stick controls	69
Stores display	69
Armament Control Panel (ACP)	70
Weapons Programming	72
UFC and ODU Weapons Programming	72
ACP Weapons Programming	73
Multiple Release	73
Weapons Acquisition & Delivery Modes	75
Air-to-Air	75
Air-to-Ground	77
Weapons Jettison	84
Emergency Jettison	84
Selective Jettison	84
ELECTRONIC WARFARE	87
Radar Warning Receiver (RWR)	87
RWR Display	87
Missile Launch Warning System (MLWS)	88
Counter Measures Dispensers (CMD)	88
Expendables loading	89
Expendables dispensing programming	90
Expendables operation	90
Dispensing	90
AN/ALQ-164 RF JAMMER POD (DECM)	91
Description	91
Characteristics	91
DECM Operation	91
AN/AAQ-28 LITENING II TARGETING POD (TPOD)	92
Description	92
Characteristics	92
TPOD Video Display	92
TPOD Operation	92
MPCD Pushbutton Controls	92

HOTAS/TDC Controls.....	92
TPOD Modes of Operation.....	93
TPOD Laser Operations.....	93
APPENDICES.....	94
Default AWLS Channel List.....	94
Default COM 1 Channel List.....	94
Default COM 2 Channel List.....	94
Aircraft Weapons Loads.....	95
Authorized Weapons.....	95
Release Sequence.....	96
Default Loads.....	96
Glossary.....	98
Default Keyboard Binds.....	99
Category: Master Modes.....	99
Category: HUD Control.....	99
Category: VSTOL Controls.....	99
Category: Stability Augmentation & Autopilot.....	99
Category: Armament Control Panel.....	99
Category: HOTAS.....	100
Category: Hydraulic & Mechanical.....	101
Category: Left MPCD.....	101
Category: Right MPCD.....	102
Category: Up Front Control.....	103
Category: Miscellaneous Controls.....	104
Category: Engine & Fuel.....	104
Category: Exterior Lights.....	104
Category: Pilot & Seat Controls.....	105

AIRCRAFT DESCRIPTION

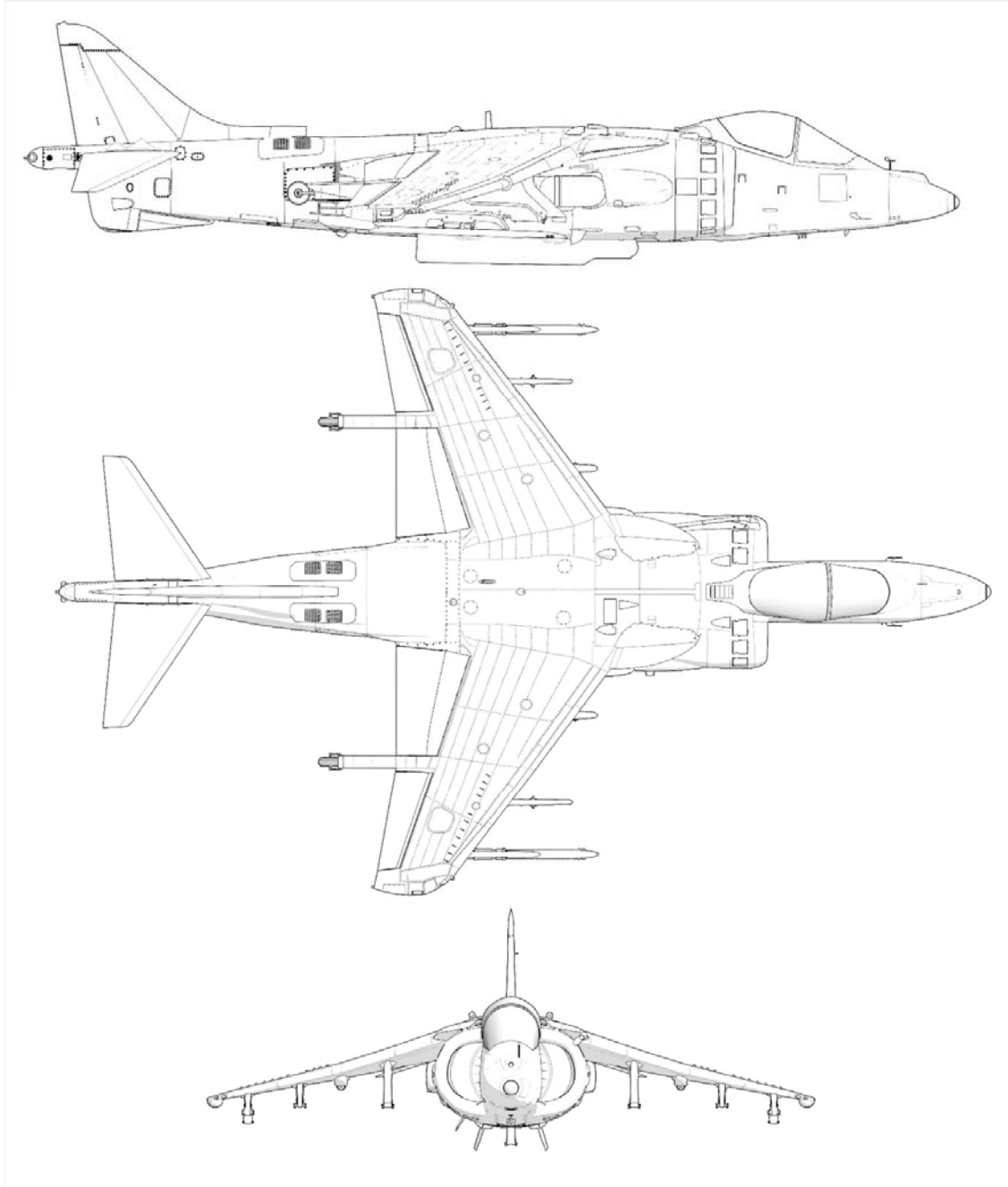

Wing Span	30.33 feet	9.24 m
Length	46.33 feet	14.12 m
Height (top of fin)	11.65 feet	3.55 m
Wing gear spread	17.00 feet	5.18 m
Empty Weight	13,968 lb	6,340 Kg
Loaded Weight	22,295 lb	10,410 Kg
Maximum takeoff weight		
Rolling	31,000 lb	14,100 Kg
Vertical	20,755 lb	9,415 Kg

COCKPIT

Main Instruments Panel

MAIN PANEL LOCATION MAP

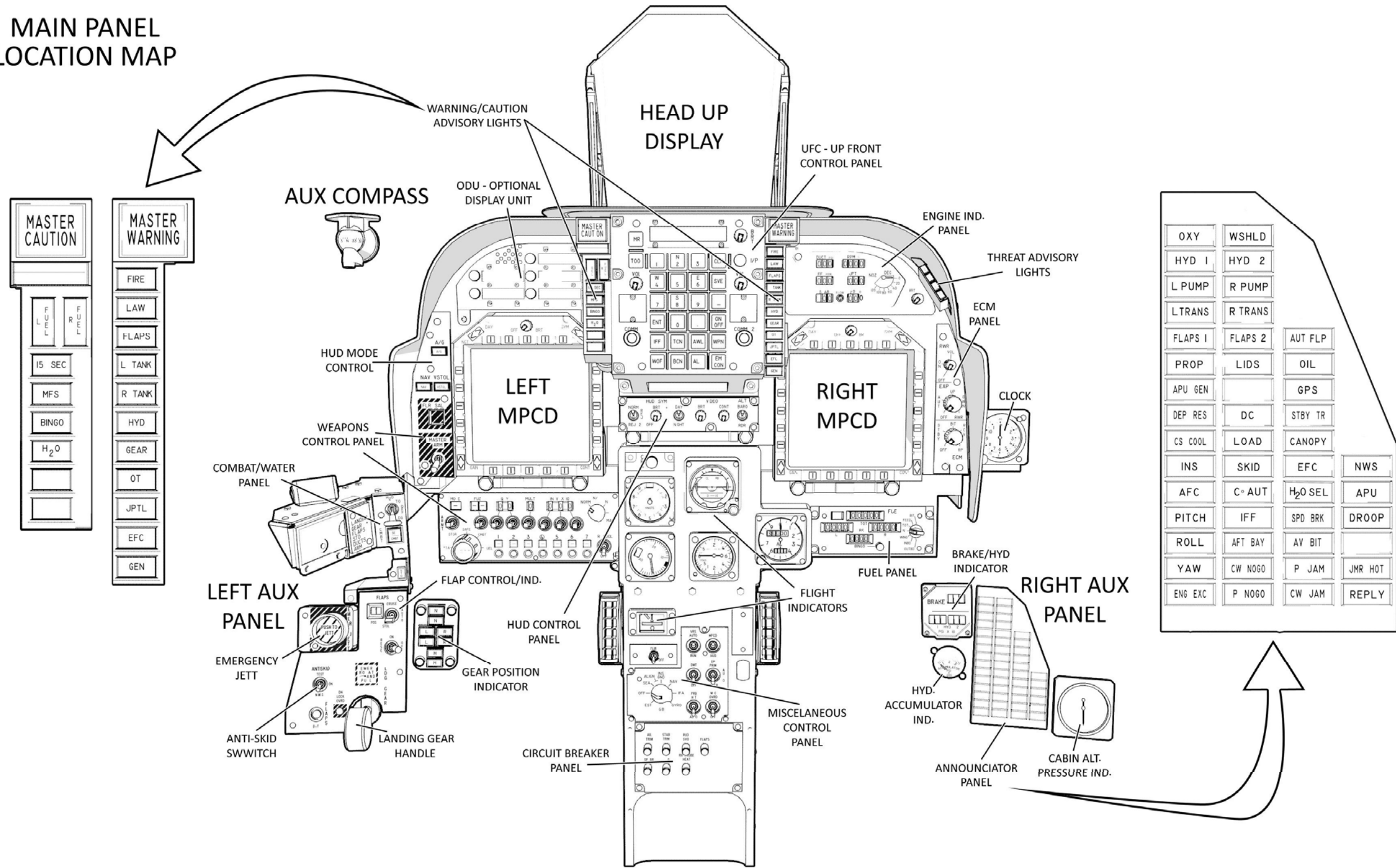

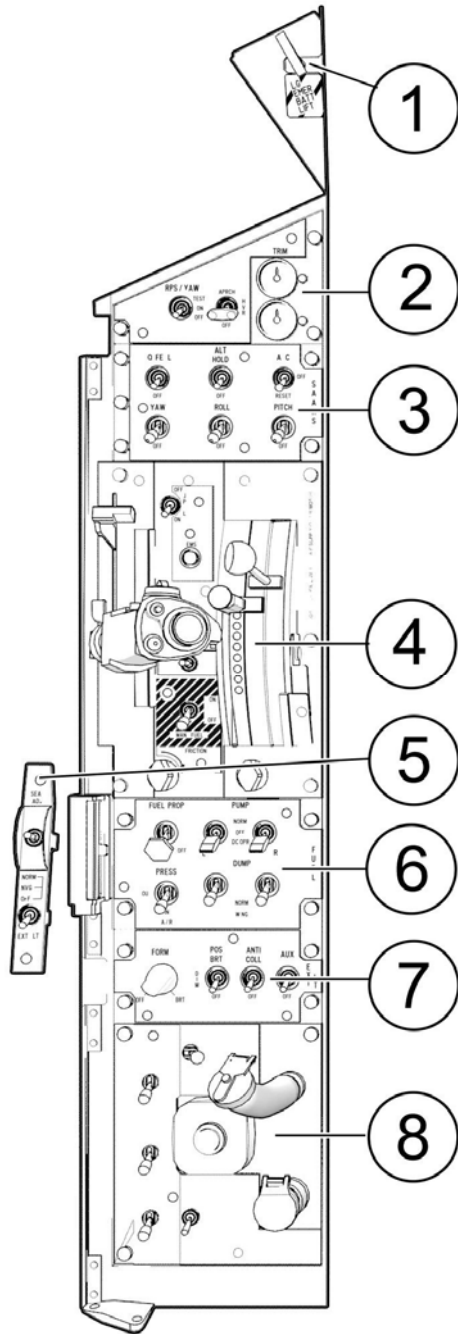

1. EMERG. BATT HANDLE

2. TRIM PANEL

- Rudder Trim Indicator
- Aileron Trim Indicator
- Landing Light Switch
- Rudder Pedal Shaker (RPS) Switch

3. SAAHS PANEL

- Altitude Hold Switch
- STAB AUG Switches
- Q Feel Switch
- AFC Switch

4. THROTTLE QUADRANT

- Engine Limiters Switch
- STO STOP Lever
- Nozzle Control Lever
- Throttle Lever
- Rudder Trim Switch
- Manual Fuel Switch
- Brake Lock Lever

5. MISC. SWITCH PANEL

- Seat Adjustment Switch
- External Lights Master Switch

6. FUEL PANEL

- Flow Proportioner
- L and R Fuel Pumps Switch
- L and R Wing Fuel Dump Switch
- Air Refueling (A/R) Switch

7. EXTERNAL LIGHTS PANEL

- Formation Lights Knob
- Position Lights Switch
- Anti-Collision Lights Switch
- Auxiliary Landing Light Switch

8. PILOT SERVICES PANEL

- Water Dump Switch
- Oxygen Switch
- LIDS Switch
- Engine RPM Select Switch
- Engine Fuel Control Switch

Right Instruments Panel

1. ELECTRICAL PANEL

DC Voltmeter
DC Test Switch
Battery Switch
Generator Switch
Engine Start Switch
APU Switch

2. V/UHF RADIO SET CONTROL

3. ACNIP PANEL

4. INTERIOR LIGHTS PANEL

Console Lights Knob
Instruments Lights Knob
Flood Lights Knob
Compass Light/Lights Test Switch
Warning/Caution Lights Knob

5. ENVIRONMENTAL CONTROL

Temperature Controller
Equipment Bay Cool Switch
RAM Air Switch
DEFOG Switch

6. NVG STOWAGE & VIDEO RECORDER

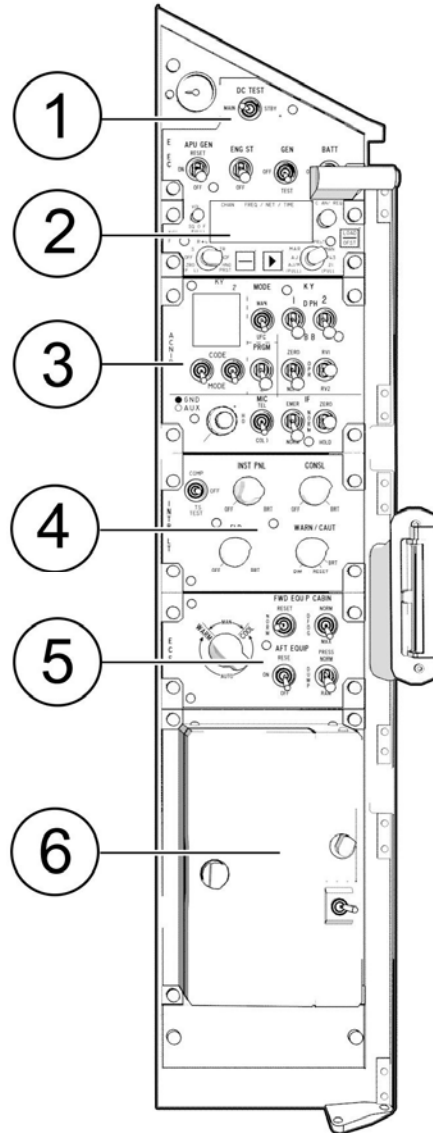

Rear Panel Left

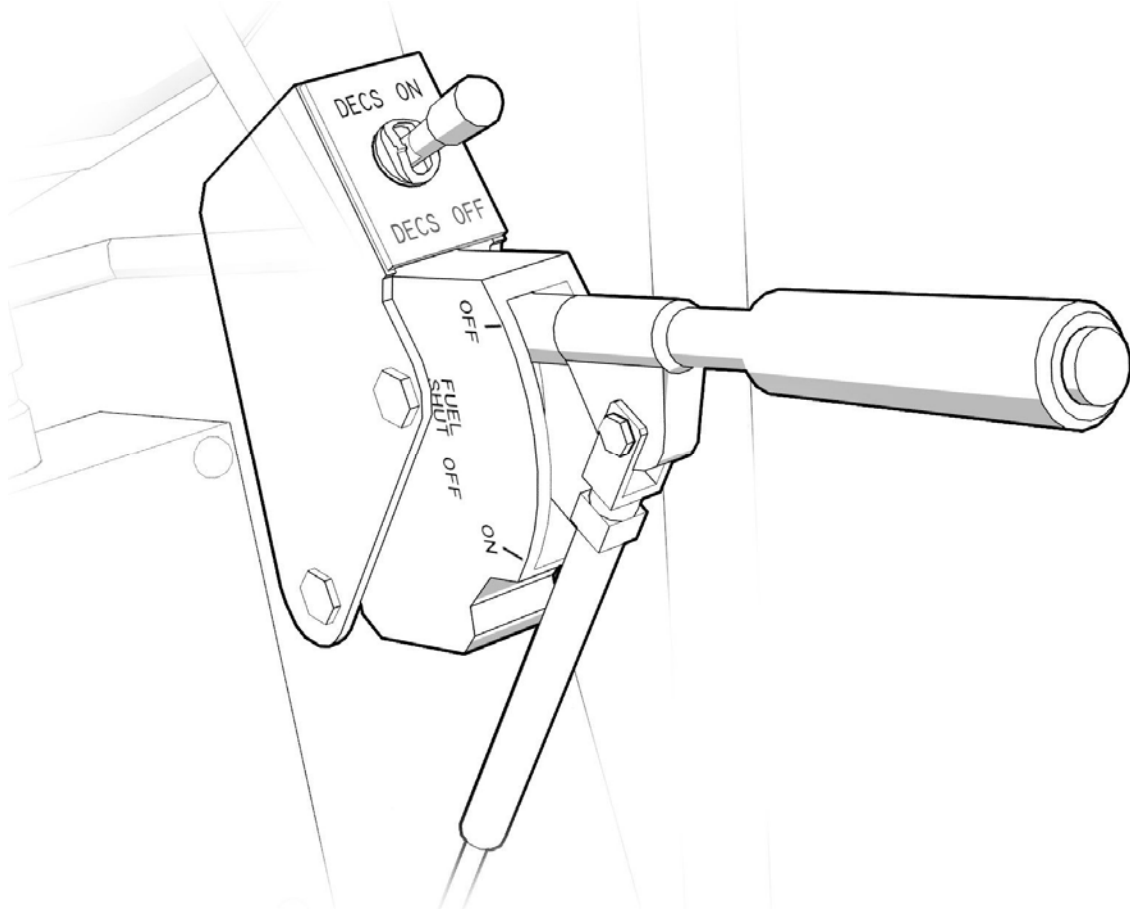

Description	Keybind
1. DECS Switch	
2. Fuel Shut Off Lever	
3. Fuel Shut Off Lever Lock	[Fuel Shutoff Lever lock release]

ATTENTION

The Fuel Shut Off lever locks in position when clicked ON. To click it OFF, the [Fuel Shutoff Lever lock release] key must be pressed first.

Rear Panel Right

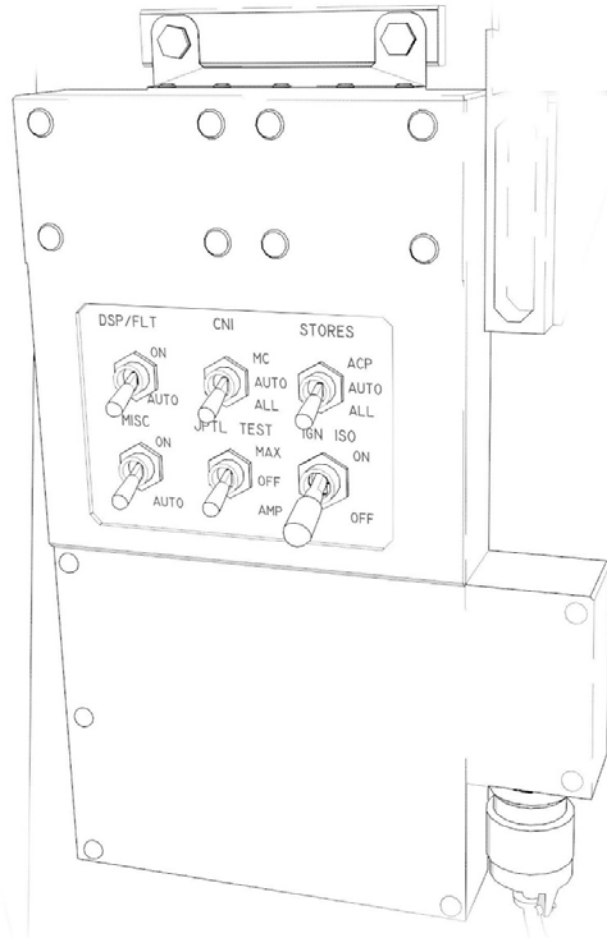

NOTE

Ground Power Control panel is not enabled in initial Early Access release. It will be enabled on subsequent updates.

Throttle Quadrant

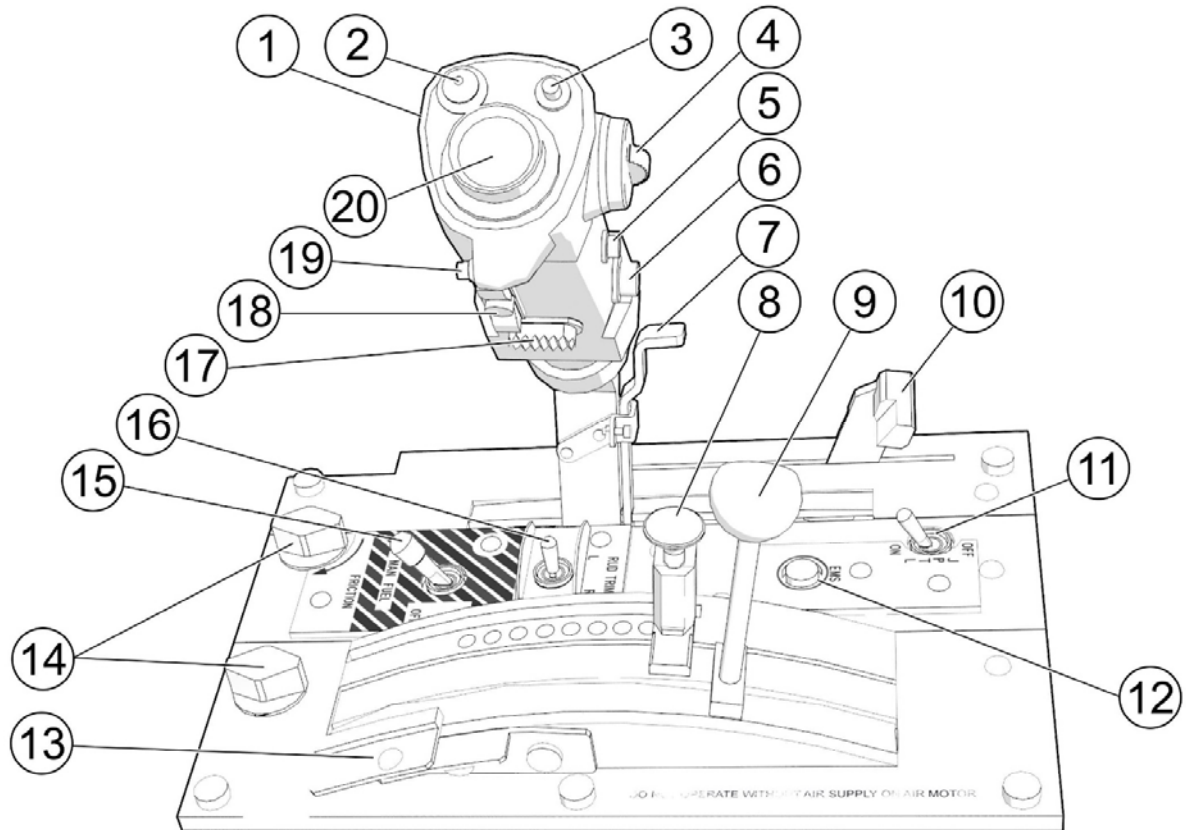

Description	Keybind
1. Throttle	[Throttle UP] [Throttle DOWN] Has AXIS Control
2. ECM Dispense Switch	[ECM Dispense FWD: Flares] [ECM Dispense AFT: Chaff] [ECM Dispense Left: Mini Jammer] [ECM Dispense Right: All]
3. Cage/Uncage Switch	[Cage/Uncage]
4. Antenna Elevation Switch	NOT OPERATIONAL ON NA
5. Airstart Switch	[Engine Airstart]
6. Emergency Flap Retract Switch	[Emergency Flap Retraction]
7. Throttle Cutoff Lever	[Throttle Cutoff]
8. Short Takeoff Stop	[STO STOP UP] [STO STOP DOWN]
9. Nozzles Control Lever	[Nozzle Rotation UP] [Nozzle Rotation DOWN] Has Axis Control

Description	Keybind
10. Parking Brake Lever	[Parking Brake ON] [Parking Brake OFF]
11. Jet Pipe Temperature Limiter Switch	
12. EMS Button	
13. Hovering Vertical Takeoff Stop	
14. Throttle and Nozzle Lever Friction Knobs	
15. Manual Fuel Control Switch	
16. Rudder Trim Switch	[Trim RUDDER LEFT] [Trim RUDDER RIGHT]
17. Speed Brake Switch	[Airbrake ON] [Airbrake OFF] [Airbrake TOGGLE]
18. COMM Switch	[COMM UP: Select COMM 1] [COMM DOWN: Select COMM 2]
19. A/A Programming	NOT OPERATIONAL ON NA
20. TDC	[TDC Forward] [TDC Aft] [TDC Left] [TDC Right] [TDC Down (Action Position)] [TDC Action/No Action Toggle] Has Axis Control

Control Stick

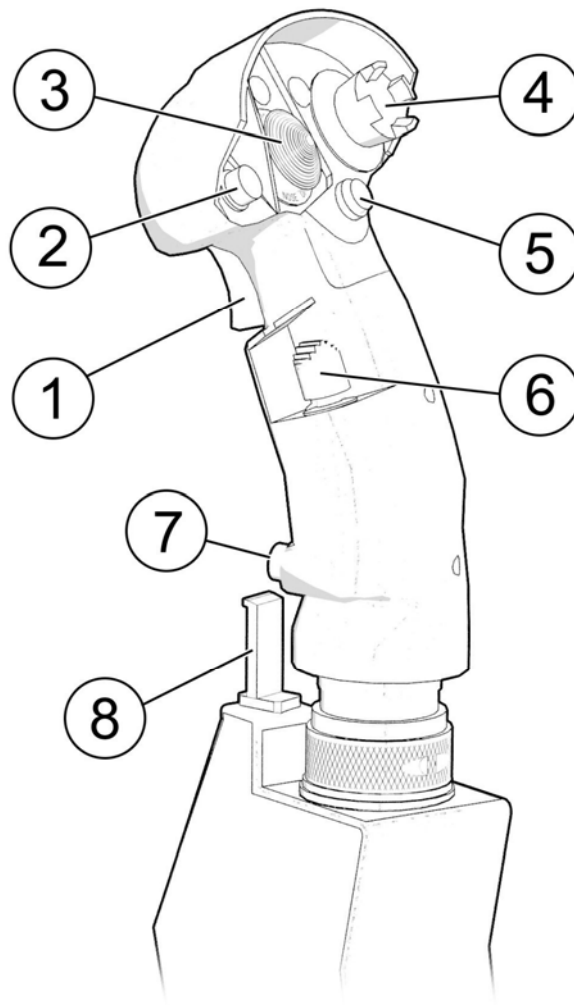

Description	Keybind
1. Trigger	[Trigger: Fire Gun/Launch Sidewinder, Sidearm]
2. Air-To-Ground Bomb Pickle Button	[Bomb Pickle: Release Bombs/Launch Rockets, Mavericks]
3. Trim Switch	[Trim Pitch UP] [Trim Pitch DOWN] [Trim Bank LEFT] [Trim Bank RIGHT]
4. Sensor Select Switch	[Sensor Select FWD: INS. IRMV/EOMV] [Sensor Select AFT: DMT: LST/TV] [Sensor Select LEFT: MAP Center/Decenter] [Sensor Select RIGHT: FLIR/HUD-BH/WH] [Sensor Select DOWN: HUD Scene Reject/TPOD]
5. Waypoint Increment	[WP Increment]

Description	Keybind
6. Air-To-Air Weapon Select Switch	[A/A Mode FWD: Sidewinder (Boresight)] [A/A Mode AFT: Sidewinder (SEAM)] [A/A Mode DOWN: Gun]
7. Undesignate/NSW Steering	[AG Target Undesignate/NWS/FOV Toggle]
8. Emergency SAAHS Disengage Switch	[Emergency SAAHS Disconnect]

AIRCRAFT SYSTEMS

The AV-8B Night Attach aircraft has the following built-in systems:

- Digital Engine Control System DECS.
- Automatic Fuel System.
- Air Refueling System.
- Electrical Power System.
- External Lighting.
- Internal Lighting.
- Hydraulic Power Supply System.
- Flight Control System
 - Primary Flight Controls:
 - Control Stick (Pitch and Roll).
 - Rudder Control.
 - Reaction Control System (RCS).
 - Secondary Flight Controls:
 - Flaps.
 - Ailerons.
 - Speedbrake.
- Stability Augmentation and Attitude Hold System SAAHS.
- Landing Systems.
- Instruments.
 - Digital Instruments.
 - Head-Up Display HUD.
 - Upfront Control UFC.
 - Option Display Unit ODU.
 - Multipurpose Color Displays MPCD.
 - Standby Instruments.
 - Angle of Attack indicator.
 - Turn and Slip Indicator.
 - Clock.
 - Stopwatch.
 - Standby Magnetic Compass.
 - Standby Vertical Velocity Indicator.
 - Standby Attitude Indicator.
 - Standby Altimeter.
 - Standby Airspeed Indicator.
- Mission Systems Computer.
- VREST Computer (for jetborne flight).
- Air Data Computer ADC.
- Environmental Control System ECS.
- On-Board Oxygen Generating System OBOGS.

NORMAL PROCEDURES AND CHECKLISTS

Engine Start

After Entering Cockpit

1. DECS enable switch OFF
2. Fuel Shutoff handle OFF
3. Engine RPM switch LO
4. EFC switch POS 1
5. LIDS switch NORM
6. Oxygen Switch OFF
7. H2O Dump switch OFF
8. Exterior Lights AS REQUIRED
9. Exterior Lights Master Switch ON
10. A/R Switch IN
11. Left and Right wing fuel dump switches NORM
12. Left and Right boost pump switches NORM
13. FUEL PROP ON
14. Throttle OFF
15. JPTL Switch ON
16. Manual fuel switch OFF
17. Parking brake ON
18. SAS SET
 - a. Pitch ON
 - b. Roll ON
 - c. Yaw ON
19. Q-feel switch ON
20. Rudder pedal shaker switch ON
21. Landing light switch OFF
22. ANTISKID switch ON
23. Landing Gear handle DOWN
24. LDG GEAR EMER BATT CHECK
25. Flaps Switches OFF
26. Water Switch OFF
27. MASTER ARM OFF
28. Armament Control Panel SAFE/NORM
29. IR Cool Switch OFF
30. MPCD, HUD and COMM AS DESIRED
31. FLIR Switch AS DESIRED
32. VRS Display Switch AS DESIRED
33. DMT Switch AS DESIRED
34. INS mode selector knob OFF
35. DP switch AUTO
36. MC switch AUTO
37. Circuit Breakers (7) IN
38. ECM control panel
 - a. RWR AS DESIRED
 - b. EXP (expendables) OFF
 - c. ECM OFF
39. Battery switch OFF
40. Generator switch GEN
41. V/UHF radio remote control AS DESIRED
42. ACNIP panel AS DESIRED
43. IFF NORM

- | | |
|---------------------------|-------------|
| 44. Internal lights panel | AS DESIRED |
| 45. ECS Panel | |
| a. Temperature controller | AUTO |
| b. Aft bay EQUIP Switch | ON |
| c. DEFOG switch | NORM |
| d. Cabin pressure switch | NORM |
| 46. Video Recorder | STBY/REMOTE |

Pre-Start

- | | |
|---|--|
| 1. Battery switch | BATT |
| 2. ICS | CHECK/SET |
| | TEST |
| 3. Warning and Caution lights | MASTER CAUTION RESET |
| 4. Brakes | CHECK |
| a. Accumulator | 1000 PSI MINIMUM |
| | 1500 PSI MINIMUM |
| b. Brake pressure | IF AIRCRAFT NOT SECURED |
| 5. Landing gear indicator | 4 GREEN |
| 6. Throttle quadrant | CHECK |
| 7. Igniters | CHECK |
| | CHECK IRREGULAR CRACKING |
| | SOUND |
| a. Depress airstart button | IF NO SOUND OR SOUND IS
REGULAR, CHECK HAS FAILED |
| | SWITCH ON |
| b. Manual fuel switch | CHECK IGNITERS |
| | SWITCH OFF |
| 8. EDP | BIT |
| | (OBSERVE THE FOLLOWING) |
| a. NOZZLE needle | 60° THEN FLUCTUATE |
| b. OT warning light | ON |
| c. 15 SEC light | ON |
| d. Water flow light | ON |
| e. Lights after BIT complete | ALL OFF |
| | CHECK QUANTITY |
| 9. Fuel Panel | BIT |
| | (OBSERVE THE FOLLOWING) |
| a. Left window | 1400 +/- 100 |
| b. Right window | 2400 +/- 100 |
| c. TOT window | 3800 +/- 200 |
| d. L and R fuel low level lights | FLASHING |
| e. LOAD caution light | ON |
| f. BINGO caution light (if bingo fuel set above 4000
pounds) | ON |
| g. LEFT and RIGHT full advisory lights | FLASHING |
| h. Lights after BIT complete | ALL OUT |
| 10. Canopy caution light switches | CHECK |
| | CHECK CONTROL HANDLE |
| a. Canopy open | FULL FORWARD AND CANOPY
CAUTION LIGHT ON |
| | CHECK CANOPY CAUTION |
| b. Pull canopy control handle full aft | LIGHT OFF |

CHECK CONTROL HANDLE
 FULL FORWARD AND CANOPY
 CAUTION LIGHT OFF

c. Canopy close

IF EXTERNAL POWER IS TO BE USED

- 11. Battery switch OFF
- 12. External electrical power CONNECT
- 13. Battery switch BATT
- 14. Ground power panel switches
 - a. AFT EQP ALL
 - b. COCKPIT ON
 - c. FWD EQP ON
 - d. STORES ACP or SMS

IF APU POWER IS TO BE USED

- 15. Canopy CLOSED
- 16. APU generator switch ON
- 17. APU Advisory light ON
- 18. APU GEN light OUT
- 19. Canopy AS DESIRED

Starting Engine

- 1. Canopy CLOSED
- 2. DECS power CHECK
- 3. External power DISCONNECT IF APPLICABLE
- 4. Parking brake ON
- 5. Throttle OFF
- 6. Nozzles AFT TO 10°
- 7. Engine start switch ENG ST
- 8. Throttle IDLE
(after indication of RPM)
- 9. Engine start switch CHECK OFF PRIOR TO 15%
- 10. Idle RPM CHECK
- 11. JPT CHECK 545°C MAXIMUM
- 12. HYD 1 and HYD 2 pressure 3000 +/- 200 PSI
- 13. Brake accumulator pressure 3000 +/- 200 PSI
- 14. Brake pressure CHECK
- 15. Nozzles 10°
- 16. Warning and Caution lights TEST
- 17. Landing gear indication 4 GREEN
- 18. MPCD, HUD, COMM ON / AS DESIRED
- 19. MPCD SELECT ENG PAGE
- 20. Canopy AS DESIRED

Before Taxiing

- 1. INS ALIGNMENT
 - a. Parking brake SET
 - b. MPCD (EHSD PAGE) CHECK A/C LAT/LONG AND
INPUT CORRECT POSITION IF
REQUIRED

c. INS switch	GND ALIGN (MANSEA if on a ship)
d. MPCD (EHSD PAGE)	
i. DTX	SELECT
ii. TRUE	UNBOXED
iii. WAYPOINTS	CHECK/ENTER
2. DMT switch	ON
3. IFF, TACAN, RADALT	ON AND SET
4. FLIR switch	ON
5. Boost pumps	CHECK
a. Left and Right pump switches OFF	PUMPS LIGHTS ON
b. Left and Right pump switches DC	PUMPS LIGHTS OFF
c. Left and Right pump switches NORM	PUMPS LIGHTS OFF
6. Transformer-rectifier	CHECK
a. DC test switch HOLD AT MAIN	Voltmeter drops. STBY TR light illuminates at 24.75 Volts.
b. DC test switch RELEASE	Voltmeter returns to above 25.5 volts
c. DC test switch HOLD AT STBY	Voltmeter drops to approximately 25.5 volts
7. JPT limiter	CHECK
8. Manual fuel switch	CHECK
9. Water switch	CHECK THEN OFF
10. FUEL PROP	CHECK THEN ON
11. Trim	CHECK THEN SET
12. Standby instruments	CHECK
13. OBOGS System	CHECK
14. Flaps	BIT
15. Flaps	CRUISE
16. Flight controls	CHECK
17. MPCD STORES	BIT CHECK
18. SAAHS	BIT
19. Paddle switch	CHECK
20. Display computer	CHJECK
21. A/R Probe	CYCLE
22. MPCD	CHECK PERFORMANCE
23. Displays/NVG	ADJUST
24. INS	CHECK STATUS PRIOR TO TAXI

Taxiing

Aircraft directional control during taxi should be via nosewheel steering since no differential braking is available.

Idle thrust is high and will result in excessive taxi speed unless the brakes are used or nozzles deflected. The use of nozzle deflection between 45° and 60° for control of taxi speed is recommended.

When taxiing with nozzles deflected, it is essential that the stick be held forward 2° nose down so that the nose RCS valve will remain closed. This will prevent the nose RCS valve from blowing debris into the engine intake ducts.

When Ready to Taxi:

- | | |
|----------------|------------|
| 1. Master Mode | VSTOL |
| 2. Nozzles | 10° |
| 3. Flaps | CRUISE |
| 4. Trim | 0°, 0°, 4° |
| 5. Anti-skid | CHECK |
| 6. Brakes/NWS | CHECK |

ATTENTION

The NWS is only engaged as long as the [AG Target Undesignate/NWS/FOV Toggle] HOTAS button remain pressed. The NWS will disengage as soon as the [AG Target Undesignate/NWS/FOV Toggle] button is released.

Pre-positioning Checks

Pre-positioning checks may be completed in the chocks, while taxiing, or while marshalling.

- | | |
|-----------------------------------|----------------|
| 1. CWAIVER checks | |
| C – Clock | SET |
| W – Weapons | PROGRAMMED |
| A – ARBS | BORESIGHT |
| FLIR | SET |
| I - IFF | SET |
| IR cool switch | AS DESIRED |
| V – VRS | AS DESIRED |
| E – ECM (ALE/ALQ/ALQ) | SET |
| R – RADALT | SET |
| 2. Canopy | CLOSED/CHECK |
| 3. Seat | ARMED |
| 4. Flight and standby instruments | CHECK |
| 5. APU | AS DESIRED |
| 6. ANTI-SKID | ON (LIGHT OUT) |
| 7. Altitude Switch | AS DESIRED |
| 8. INS Knob | IFA/NAV |
| 9. Approach Light | ON |

Takeoff

Four methods of takeoff are possible:

- Vertical Takeoff (VTO).
- Rolling Vertical Takeoff (RVTO).
- Short Takeoff (STO).
- Conventional Takeoff (CTO).

Takeoff Checklist

The following checklist is used to configure the aircraft for all four takeoff methods.

NOTE

Each aircraft cockpit contains a takeoff checklist placard. The contents of these placards vary substantially from the takeoff checklist described in this manual.

The Takeoff Checklist consist of two parts:

Aircraft Configuration Check: Also referred to as One Finger check because it is initiated and confirmed by signaling with the index finger extended.

Engine, Water System & Flight Control Check: Referred as a Two Finger or Five Finger check depending whether water is being used or not. In this check the pilot evaluates engine performance, flap programming and nozzle movement, as well as arming the water system, if required.

By default, Pitch Carets (PC) are set at 14 for all takeoffs. This places the pitch carets at 6° elevation with respect to the horizon bars in VSTOL Master Mode. This position indicates the desired post-takeoff placement of the Depressed Attitude Symbol (or Witch Hat). This takeoff attitude is the level equivalent of 14° AOA.

Trim for both aileron and rudder shall be 0°. Pitch trim for shore-based takeoffs shall be 2° Nose Down.

Check the specific takeoff procedures for additional detail.

Aircraft Configuration Check (On Finger Checks)

- | | |
|------------------------------------|-------------|
| 1. Nozzle Rotation Airspeed (NRAS) | AS REQUIRED |
| 2. Pitch Carets (PC) | SET |
| 3. STO Stop | AS REQUIRED |
| 4. Trim | SET |
| 5. Flaps | AS REQUIRED |
| 6. Warning/Caution lights | OUT |

NOTE

To set the NRAS or PC:

- Press the VSTOL Master Mode button.
- For NRAS, select the NRAS option on ODU. Insert NRAS on the UFC. Press ENTER.
- For PC, select PC on ODU. Insert 14 on UFC. Press ENTER

ATTENTION: NRAS and PC values are fixed for the initial Early Access release version. The pilot cannot change them.

Engine, Water System & Flight Control Check (Two/Five Finger Checks)

- | | |
|--|------------------------------------|
| 7. Engine | CHECK |
| a. MPCD (Left or Right) | Select ENG |
| b. Accelerate engine from idle to 60% | |
| c. Check acceleration time within limits: | 35 to 60%
in 2.4 – 3.1 seconds. |
| d. IGV's | 10 to 21° at 60% |
| 8. Water | AS REQUIRED |
| a. Place water switch to TO and note RPM rise. | |
| b. Reset RPM to top end of acceleration band. | |
| 9. Nozzle/flaps/duct pressure | CHECK |
| a. Set nozzles momentarily to STO stop (or 50° is STO stop is not required). | |
| b. Check flaps for proper angle based on flap mode. | |
| c. Check duct pressure approx. 45 PSI. | |
| d. Place nozzles at the takeoff position. | |

Jetborne/Semi-jetborne Takeoffs

All jetborne and semi-jetborne takeoffs begin with a takeoff procedure and end with an accelerating transition to wingborne flight. The transition point between the takeoff procedure and the accelerating transition procedure begins once the aircraft is off the ground, the wings are level and the vane is centered. At this point, attitude and AOA can be safely increased and the Accelerating Transition can begin.

Vertical Takeoff (VTO)

If possible, VTO into the wind. Lateral control during the first few feet of a VTO is critical, do not hesitate to make immediate, large and rapid control movements to counteract bank angles.

Aircraft Configuration Check (On Finger Checks)

- | | |
|------------------------------------|--------------|
| 1. Nozzle Rotation Airspeed (NRAS) | NOT REQUIRED |
| 2. Pitch Carets (PC) | SET |
| 3. STO Stop | CLEAR |
| 4. Trim | SET |
| 5. Flaps | STOL |
| 6. Warning/Caution Lights | OUT |

Engine, Water System & Flight Control Check (Two/Five Finger Checks)

- | | |
|---|-------------|
| 7. Engine | CHECK |
| 8. Water | AS REQUIRED |
| 9. Nozzle/Flaps/Duct Pressure | CHECK |
| a. Set nozzles momentarily to approximate 50° | |
| b. Check flaps at approximately 62° | |
| c. Check duct pressure at approximately 45 PSI | |
| d. Place nozzles at the HOVER Stop and check angle. | |

Initiate Takeoff

- | | |
|--|--|
| 10. Throttle | FULL |
| 11. Brakes | HOLD until airborne |
| 12. Engine | CHECK TOP END RPM and
Water Flow (if armed) |
| 13. During liftoff: Ensure wings remain level. Hold heading and adjust attitude to prevent fore/aft drift. | |
| 14. When clear of ground effect (20 – 25 feet), gradually reduce power to establish a hover, or when passing 50 feet and clear of obstacles, being transition to wingborne flight. | |

Rolling Vertical Takeoff (RVTO)

The RVTO requires approximately 100 feet of ground roll and should be made as nearly into the wind as possible.

Aircraft Configuration Check (On Finger Checks)

- | | |
|------------------------------------|--------------|
| 1. Nozzle Rotation Airspeed (NRAS) | NOT REQUIRED |
| 2. Pitch Carets (PC) | SET |
| 3. STO Stop | SET 70° |
| 4. Trim | SET |
| 5. Flaps | STOL |
| 6. Warning/Caution Lights | OUT |

Engine, Water System & Flight Control Check (Two/Five Finger Checks)

- | | |
|--|-------------|
| 7. Engine | CHECK |
| 8. Water | AS REQUIRED |
| 9. Nozzle/Flaps/Duct Pressure | CHECK |
| a. Set nozzles momentarily to STO Stop and check angle | |
| b. Check flaps at approximately 62° | |
| c. Check duct pressure at approximately 45 PSI | |
| d. Place nozzles to 30° | |

Initiate Takeoff

- | | |
|---|--|
| 10. NWS | ENGAGE |
| 11. Throttle | FULL |
| 12. Brakes | RELEASE |
| 13. Nozzles | STO STOP AS RPM PASSES
110% |
| 14. Engine | CHECK TOP END RPM and
Water Flow (if armed) |
| 15. During liftoff ensure wings remain level and center the slideslip vane. | |
| 16. Begin transition to wingborne flight. | |

Short Takeoff (STO)

The STO can be used for the widest variety of aircraft configuration, weight and runway conditions provided that crosswinds remain within specified limits.

Aircraft Configuration Check (On Finger Checks)

- | | |
|------------------------------------|---------------------------|
| 1. Nozzle Rotation Airspeed (NRAS) | SET AS CALCULATED |
| 2. Pitch Carets (PC) | SET |
| 3. STO Stop | SET AS CALCULATED |
| 4. Trim | SET |
| 5. Flaps | AS DESIRED (STOL or AUTO) |
| 6. Warning/Caution Lights | OUT |

Engine, Water System & Flight Control Check (Two/Five Finger Checks)

- | | |
|--|-------------|
| 7. Engine | CHECK |
| 8. Water | AS REQUIRED |
| 9. Nozzle/Flaps/Duct Pressure | CHECK |
| a. Set nozzles momentarily to STO Stop and check angle | |
| b. Check flaps for proper angle based on flap mode | |
| c. Check duct pressure at approximately 45 PSI | |
| d. Place nozzles to 10° | |

Initiate Takeoff

- | | |
|--------------|--|
| 10. NWS | ENGAGE |
| 11. Throttle | FULL |
| 12. Brakes | RELEASE |
| 13. Engine | CHECK TOP END RPM and
Water Flow (if armed) |

14. Nozzles

STO STOP AT CALCULATED
NRAS

15. During liftoff ensure wings remain level and center the slideslip vane.

16. Begin transition to wingborne flight.

Accelerating Transition (AT)

Accelerating Transition is the term used to describe transition from jetborne/semi-jetborne flight to wingborne flight. The AT begins when the aircraft is clear of ground effect and at an altitude sufficient to avoid obstacles and introduction of FOD onto the landing surface.

WARNING

During AT, AOA must not exceed 15°. Over-rotation or high rotational rates may result in the AOA rising uncontrollably even with stick full forward. Uncontrollable pitch ups are most likely to occur at extreme aft CG loadings and/or with the wing flaps deflected more than 25°.

- | | |
|-------------|--|
| 1. Throttle | FULL |
| 2. Attitude | SET WITCH HAT AT THE PITCH CARETS
Continue to maintain wings level and vane centered. |
| 3. Nozzles | GRADUALLY ROTATE THE NOZZLES AFT.
Maintain nozzle angle of 25° or greater while in STOL flaps
Nozzle rotation should enable the aircraft to maintain a slight climb. |

Once wingborne flight is achieved

4. Reduce power to achieve normal lift dry rating or less and stop water flow (if required).
5. Perform After Takeoff Check or enter the landing pattern.

Conventional Takeoff (CTO)

The CTO can be used when configuration or environmental conditions preclude use of any other takeoff type (i.e. crosswinds or asymmetric loadings). The CTO is restricted to gross weights that will not cause the wheel/tire limitation speed of 180 KGS to be exceeded on the takeoff roll.

Aircraft Configuration Check (One Finger Checks)

- | | |
|------------------------------------|-----------------------|
| 1. Nozzle Rotation Airspeed (NRAS) | SET NSW LIFTOFF SPEED |
| 2. Pitch Carets (PC) | SET |
| 3. STO Stop | CLEAR |
| 4. Trim | SET |
| 5. Flaps | AUTO |
| 6. Warning/Caution Lights | OUT |

Engine, Water System & Flight Control Check (Two/Five Finger Checks)

- | | |
|---|-------------|
| 7. Engine | CHECK |
| 8. Water | AS REQUIRED |
| 9. Nozzle/Flaps/Duct Pressure | CHECK |
| a. Set nozzles momentarily to approximately 50° | |
| b. Check flaps at approximately 25° | |
| c. Check duct pressure at approximately 45 PSI | |
| d. Place nozzles to 10° | |

Initiate Takeoff

- | | |
|---|--|
| 10. NWS | ENGAGE |
| 11. Throttle | FULL |
| 12. Brakes | RELEASE |
| 13. Engine | CHECK TOP END RPM and
Water Flow (if armed) |
| 14. At nosewheel liftoff speed – Gradually rotate with aft stick. Guard against overrotation. | |
| 15. During liftoff ensure wings remain level and center the slideslip vane. | |
| 16. Set attitude – Witch Hat at the pitch carets. | |

After Takeoff

- | | |
|-----------------|------------------------|
| 1. Landing Gear | UP |
| 2. Flaps | AUTO |
| | Nozzles must be at 25° |
| 3. Nozzles | AFT |
| 4. Water switch | OFF |
| 5. STO Stop | CLEAR |

Landing

The break speed is 350 KCAS. The standard break interval is 2 seconds. At the break, apply bank angle, retard the throttle and extend speed brake. Once below 250 KCAS, complete the Landing Checklist. Four methods of landing are possible:

- Vertical Landing (VL).
- Rolling Vertical Landing (RVL).
- Slow Landing (SL).
- Conventional Landing (CL).

The method of landing must be predetermined in order to properly configure the aircraft.

A decelerating transition from wingborne flight is used to place the aircraft in position for a VL or RVL. All other landing types use a standard pattern approach to landing. On all rolling landings (CL, SL, RVL) the recommended landing attitude is to place the depressed attitude symbol (Witch Hat) on to 2° above the horizon bar.

Power Nozzle Braking (PNB) is normally used for most roll-on landings; however, the aircraft can be stopped using wheel brakes alone.

Landing Checklist

The following landing checklist is used to configure the aircraft for all four of the landing methods.

NOTE

Each aircraft cockpit contains a landing checklist placard. The contents of these placards vary substantially from the takeoff checklist described in this manual.

- | | |
|-------------|--|
| 1. Gear | DOWN |
| 2. Flaps | AS REQUIRED |
| | Nozzles must be at 25° or greater prior to selecting STOL
flap. |
| 3. STO Stop | CLEAR |

- | | |
|---|-----------------------------|
| 4. Duct pressure | CHECK |
| 5. Brake pressure | CHECK |
| 6. Water | AS REQUIRED |
| <i>If water is to be used</i> | |
| a. Water switch | T/O
(check for RPM rise) |
| b. Throttle | FULL |
| c. Check for green water flow light or W in the HUD, acceleration to short lift wet RPM and water quantity countdown. | |
| d. Water switch | AS REQUIRED |
| 7. Warning and caution lights | CHECK |
| 8. Lights | AS REQUIRED |

Decelerating Transition to a Hover

Decelerating transitions for VLs are started from a key position approximately 0.5 NM from the touchdown point (preferably downwind) at an altitude of approximately 310 feet AGL. This places the aircraft on a slightly descending flight path toward a point abeam the intended point of landing at approximately 150 feet AGL. From, or just prior to arrival at, this abeam position the aircraft then crosses to hover directly over the intended point of landing.

Approaching 180

- | | |
|------------|-----------------------------|
| 1. Nozzles | 40 – 60° |
| 2. Flaps | Check programming and droop |
| 3. AOA | 10 – 12° |

Off the 180

4. Adjust flight path with stick
5. Control AOA with throttle or nozzles

At the Key

- | | |
|--|--------------------------|
| 6. Set attitude | WITCH HAT ON THE HORIZON |
| 7. Nozzles | HOVER STOP |
| 8. Minimize sideslip, ensure no more than 15° AOA and strive for 0° AOB until less than 60 knots. Increase power as required to maintain a shallow glideslope (approx. 3°) to arrive abeam the landing site at 150 feet AGL. | |

At 60 KCAS

9. Check for adequate performance margin. If more than two legs of the power hexagon then execute a wave off.
10. Approaching landing site. Select ground references and monitor rate of closure. When closure is under control and below 30 knots, cross over the landing site while remaining at 150 feet AGL minimum until over a prepared surface. Flare slightly to spot or use braking stop as required, and establish hover over the desired landing point.

The Hover

The hover may be entered from decelerating transition or a VTO. It is an interim period during which the aircraft is held relatively stationary at an altitude of 50 to 60 feet AGL.

1. Control height with small throttle changes.
2. Maintain position with ground references.
3. RPM/JPT

WITHIN LIMITS

Vertical Landing (VL)

The VL is commenced from a 50 to 60 feet AGL hover. Landing should be made pointing into the wind to minimize exhaust reingestion.

1. Start a slow descent with the throttle.
2. Monitor ground references.
3. Maintain heading and adjust attitude and roll as necessary to correct for drift.
4. Maintain positive rate of descent.

When positively down

- | | |
|-------------|-------------------|
| 5. Throttle | IDLE |
| 6. Brakes | APPLY |
| 7. Nozzles | AFT |
| 8. Trim | 4° NOSE DOWN |
| 9. Water | OFF (if selected) |

Decelerating Transition to a Rolling Vertical Landing.

The RVL should be used when the landing surface isn't long enough to support a SL, but the landing area cannot support a VL because it is subject to damage from heating or is a source of FOD.

Decelerating transitions for RVL are started from a key position approximately ¾ NM from the touchdown point at an altitude of approximately 310 feet AGL. At the key, the aircraft attitude and estimated nozzle angle are set while a crabbed approach is used to maintain runway centerline. The aircraft is flown on a slightly descending flight path (approx. 3°) until the touchdown point reaches the desired level of depression in the HUD. At this point, flight path can be adjusted to ensure precise landing on centerline and at the desired point.

Normally a glideslope of three degrees will satisfy to control touchdown point and rollout distance. However, a steeper glideslope, up to six degrees, may be necessary when approaching over significant obstacles into short fields.

If FOD is a concern, a ground speed of 60 knots or higher will be required, otherwise groundspeeds slower than 60 knots can be considered.

Approaching 180

- | | |
|------------|-----------------------------|
| 1. Nozzles | 40 – 60° |
| 2. Flaps | Check programming and droop |
| 3. AOA | 10 – 12° |

Off the 180

4. Adjust flight path with stick
5. Control AOA with throttle or nozzles

At the Key

- | | |
|-----------------|--|
| 6. Set attitude | WITCH HAT ON THE HORIZON |
| 7. Nozzles | AS REQUIRED |
| | (adjust to maintain desired groundspeed) |

8. Minimize sideslip, ensure no more than 15° AOA.
9. Adjust power to intercept desired glideslope to touchdown point.

At touchdown

- | | |
|------------------------|---|
| 10. Throttle | IDLE |
| 11. Nosewheel steering | ENGAGE WHEN ROLLING TRAIHT AND PEDALS ARE NEUTRALIZED |
| 12. Nozzles | AS SET |
| 13. Brakes | APPLY |
| 14. Trim | MINIMUM 2° ND |
| 15. Water | OFF |
| 16. Nozzles | LESS THAN 60° WHEN SLOW |

Slow Landing (SL)

The SL is used when aircraft gross weight is too high for a VL or RVL or to reduce engine stress. There are two basic types of Slow Landing:

Fixed Nozzle Slow Landing

The recommended slow landing technique is the Fixed Nozzle Slow Landing using STOL flaps. The use of AUTO flaps is recommended when crosswinds conditions are heavy or when dealing with high asymmetric store loadings.

Approaching 180

- | | |
|------------|-----------------------------|
| 1. Nozzles | 40 – 60° |
| 2. Flaps | Check programming and droop |
| 3. AOA | 10 – 12° |

Off the 180

4. Adjust flight path with stick
5. Control AOA with throttle or nozzles

At 30 – 50 feet AGL

- | | |
|---|-----------------------------------|
| 6. Set attitude | WITCH HAT ON 2° ABOVE THE HORIZON |
| 7. Control Rate of Descent with throttle (200 – 400 fpm). | |

At touchdown

- | | |
|-----------------------|---|
| 8. Throttle | IDLE |
| 9. Nosewheel Steering | ENGAGE WHEN ROLLING TRAIHT AND PEDALS ARE NEUTRALIZED |
| 10. Nozzles | AS REQUIRED
(up to full braking stop) |
| 11. Trim | MINIMUM 2° ND |
| 12. Throttle | AS REQUIRED |

At 60 Knots

- | | |
|--------------|------------|
| 13. Throttle | IDLE |
| 14. Nozzles | HOVER STOP |
| 15. Brakes | APPLY |
| 16. Water | OFF |

17. Nozzles

LESS THAN 60° WHEN SLOW.

Variable Nozzle Slow Landing

The VNSL is used whenever the throttle needs to remain at a relatively constant setting throughout the approach, for example when the engine reliability is suspect

Approaching 180

- | | |
|-------------|------------------------------------|
| 1. Nozzles | 40 – 60° |
| 2. Throttle | 80 – 100% |
| 3. Nozzles | AS REQUIRED TO ACHIEVE 8 – 10° AOA |
| 4. Flaps | Check programming and droop |

Off the 180

5. Adjust flight path with stick
6. Control AOA with throttle or nozzles

At 30 – 50 feet AGL

7. Set attitude WITCH HAT ON 2° ABOVE THE HORIZON
8. Control Rate of Descent with throttle (200 – 400 fpm).

At touchdown

- | | |
|------------------------|--|
| 9. Throttle | IDLE |
| 10. Nosewheel Steering | ENGAGE WHEN ROLLING STRAIGHT AND
PEDALS ARE NEUTRALIZED |
| 11. Nozzles | AS REQUIRED
(up to full braking stop) |
| 12. Trim | MINIMUM 2° ND |
| 13. Throttle | AS REQUIRED |

At 60 Knots

- | | |
|--------------|--------------------------|
| 14. Throttle | IDLE |
| 15. Nozzles | HOVER STOP |
| 16. Brakes | APPLY |
| 17. Water | OFF |
| 18. Nozzles | LESS THAN 60° WHEN SLOW. |

Conventional Landing (CL)

The CL requires substantially greater distance to stop than a SL or RVL. Landing distance available is a critical consideration when performing a CL. The brakes are designed primarily for V/STOL and are marginal for a CL without Power Nozzle Braking (PNB); therefore, always use PNB when performing a CL. CLs without using PNB is an emergency procedure only.

Approaching 180

- | | |
|------------|-----------------|
| 1. Nozzles | AFT |
| 2. Flaps | Recheck in AUTO |
| 3. AOA | 10 – 12° |

Off the 180

4. Adjust flight path with stick
5. Control AOA with throttle or nozzles

At 30 – 50 feet AGL

6. Set attitude
7. Control Rate of Descent with throttle.

WITCH HAT ON 2° ABOVE THE HORIZON

At touchdown

8. Throttle
9. Nosewheel Steering

10. Nozzles

11. Trim
12. Throttle

IDLE
ENGAGE WHEN ROLLING TRAIIGHT AND
PEDALS ARE NEUTRALIZED
AS REQUIRED
(up to full braking stop)
MINIMUM 2° ND
AS REQUIRED
(for PNB a maximum of 70%)

At 60 Knots

13. Throttle
14. Nozzles
15. Brakes
16. Water
17. Nozzles

IDLE
HOVER STOP
APPLY
OFF
LESS THAN 60° WHEN SLOW.

After Landing

When clear of the active runway

1. Trim
2. Flaps
3. Water
4. IFF
5. Master Arm Switch
6. Ground safety control handle
7. Oxygen Switch
8. APU
9. Landing light

4° ND
CRUISE FOR TAXI
OFF
HOLD, WAIT FOR 10 SECONDS THEN AS DESIRED
OFF
UP
OFF
OFF
OFF

When parked

10. Nozzles
11. Parking brake
12. ANTISKID switch
13. Flap switches
14. INS update
15. FLIR switch
16. INS Switch

0 to 10°
SET
ON
OFF
PERFORM / ACCEPT IF APPLICABLE
AS DESIRED
OFF

Engine shutdown

17. Throttle

GROUND IDLE

- | | |
|---------------------------|------|
| 18. Throttle cutoff lever | LIFT |
| 19. Throttle | OFF |

After Engine shutdown

- | | |
|------------------------------|--|
| 20. Fuel boost pump switches | NORM |
| 21. DECS enable switch | OFF |
| 22. Fuel shutoff handle | OFF |
| | (click on the [Fuel Shutoff Lever lock release] before trying to click the handle to the OFF position) |
| 23. Battery switch | OFF |

Air Refueling

Aerial refueling operations are authorized with all USN tankers and the KC-10. All tanker limits apply. Ferry loading CG must be maintained by keeping the maximum water quantity below 250 pounds.

Before Plug-in checklist

- | | |
|----------------------|---|
| 1. Master Arm switch | OFF |
| 2. A/R switch | OUT
(READY light ON) |
| 3. Probe light | AS DESIRED |
| 4. Airspeed | 190 to 300 KNOTS |
| 5. AOA | 13° MAXIMUM |
| 6. Flaps | CRUISE
STOL flaps may be used to maintain AOA below 13°.
Use of AUTO flaps is prohibited. |
| 7. AFC | ENGAGE IF DESIRED
(Reduces workload) |
| 8. Visor | DOWN |

Refueling

Refueling altitudes and airspeeds are dictated by receiver and/or tanker characteristics and operational needs. This covers a practical spectrum, from the deck to 35,000 feet and 190 to 300 knots.

Approach

1. Complete the before plug-in checklist.
2. Assume a position 10 to 15 feet in trail of the drogue.
3. Keep the refueling probe in both the horizontal and vertical reference planes.
4. Trim the aircraft to keep this stabilized approach.
5. Select the drogue as the primary reference point on the tanker.
6. Set the power to establish an optimum 3 to 5 knots closure rate on the drogue.
7. Small corrections in the approach phase are acceptable:
 - a. Small lateral corrections are made with the rudder.
 - b. Small vertical corrections are made with the stabilator.
 - c. Avoid corrections in the longitudinal axis. They cause probe displacement in both the lateral and vertical reference planes.
8. If alignment is off in the final phase abort and do over.

Missed Approach

If the receiver probe passes forward of the drogue basket without making contact, a missed approach should be initiated immediately.

1. Reduce power to establish a separation rate of 3 to 5 knots.
2. Assume a position 10 to 15 feet in trail of the drogue
3. Start a new approach.

Contact

1. READY light goes out
2. Fly a close tail chase formation with the tanker.
3. LEFT and RIGHT advisory lights come on as follows:
 - a. With no external tanks: Flashing when internal wing tanks are full.
 - b. With two external tanks: Flashing when the external tanks are full.
 - c. With four external tanks: Steady when the inboard external tanks are full and flashing when the outboard external tanks are full.
4. Disengage.

Disengagement

1. Reduce power to establish a separation rate of 3 to 5 knots.
2. Keep the same alignment on the tanker as if approaching.
3. When clear of the drogue place the A/R switch to IN
4. LEFT and RIGHT advisory lights will go out when the probe is fully retracted or if PRESS selected.

AIRCRAFT LIMITATIONS

Engine Limits

RATING	Notes	LIMITATIONS							
		MAXIMUM % RPM	MAXIMUM °C JPT	COMBINED TIME LIMITS					
SHORT LIFT WET	1	120.0	800	<table border="1"> <tr> <td>A</td> <td>B</td> <td>C</td> <td>D</td> <td>E</td> </tr> </table>	A	B	C	D	E
A	B	C	D		E				
SHORT LIFT DRY		113.5	780						
NORMAL LIFT WET	1, 2	116.0	780						
NORMAL LIFT DRY	2	111.0	765						
COMBAT		111.0	750						
MAXIMUM THRUST		109.0	710						
MAXIMUM CONTINUOUS	2	102.0	645	UNLIMITED					
IDLE	5	28.4 – 29.0	545	UNLIMITED					
STARTING	2, 4		475	MOMENTARILY					
<ol style="list-style-type: none"> Do not use water injection below ambient temperatures of -5°C or at altitude above 10,000 feet. Requires pilot action to maintain limit. Each 2.5 or 10.0 minute period of operation at the lift or combat ratings respectively must be separated by a minimum of 1 minute at maximum thrust or below. Slow or abortive starting attempts should be discontinued without waiting for JPT to reach 475°C. The minimum allowable sub-idle RPM is 22% 				<ol style="list-style-type: none"> 15 Seconds 1.5 Minutes 2.5 Minutes 10.0 Minutes 15.0 Minutes 					

Notes

- Corrected fan speed is limited to 116.8% (+/- 0.5%) below 10,000 feet MSL and 110.5% (+/- 0.5%) above 30,000 feet.
- When manual fuel is selected, pilot action is required to maintain all engine limits.
- Maximum overspeed is 122% for 15 seconds or 124.0%

Engine Airstart Envelope

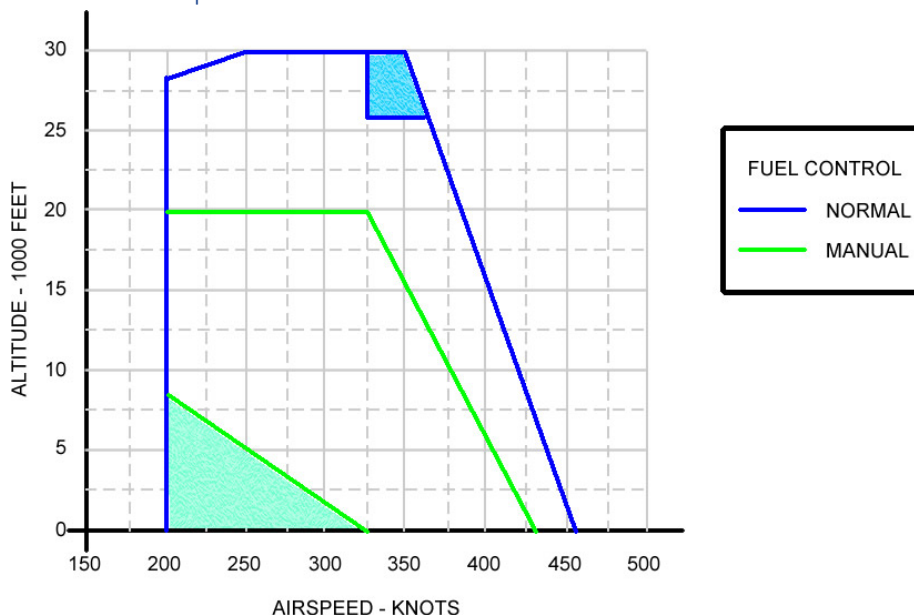

Notes

- **Blue Region:** Airstarts attempts in this region may require in excess of 15 seconds for light-off.
- **Green Region:** When the aircraft is in this region, there may not be enough time to relight the engine. Once relight has begun it may require over 30 seconds to reach IDLE rpm.

Airspeed Limitations

The maximum permissible airspeeds for flight in smooth or moderately turbulent air with landing gear, flaps and speed brake retracted, and Q-feel engaged is shown in the following chart:

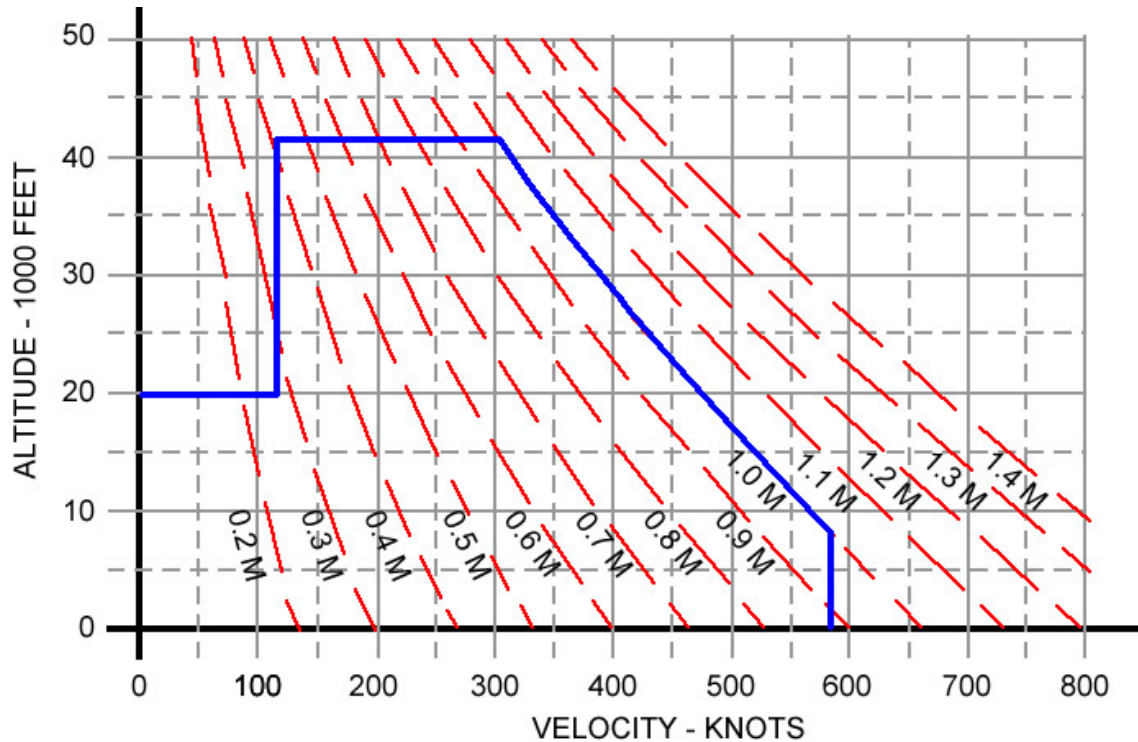

The maximum permissible airspeed/Mach number, whichever is less: 585 KCAS/1.0 IMN

Airspeed limitations for various systems are as follows:

1. Flaps:
 - a. STOL: 300 knots
 - b. CRUISE: 0.87 Mach
2. Landing gear:
 - a. Operation: 250 knots
 - b. Locked down: 250 knots
 - c. Emergency extension: 210 knots
3. Q-feel disengaged: 500 knots.
4. One hydraulics system inoperative: 500 knots.
5. Canopy open: 40 knots.
6. Wheels in contact with ground: 180 knots ground speed.
7. Lids fence extended: 200 knots.
8. Air refueling probe extended: 300 knots.

AOA Limitations

AOA limits versus Mach number when flaps are in AUTO, SAAHS is OFF and Nozzles are at 0° are in the following graphic:

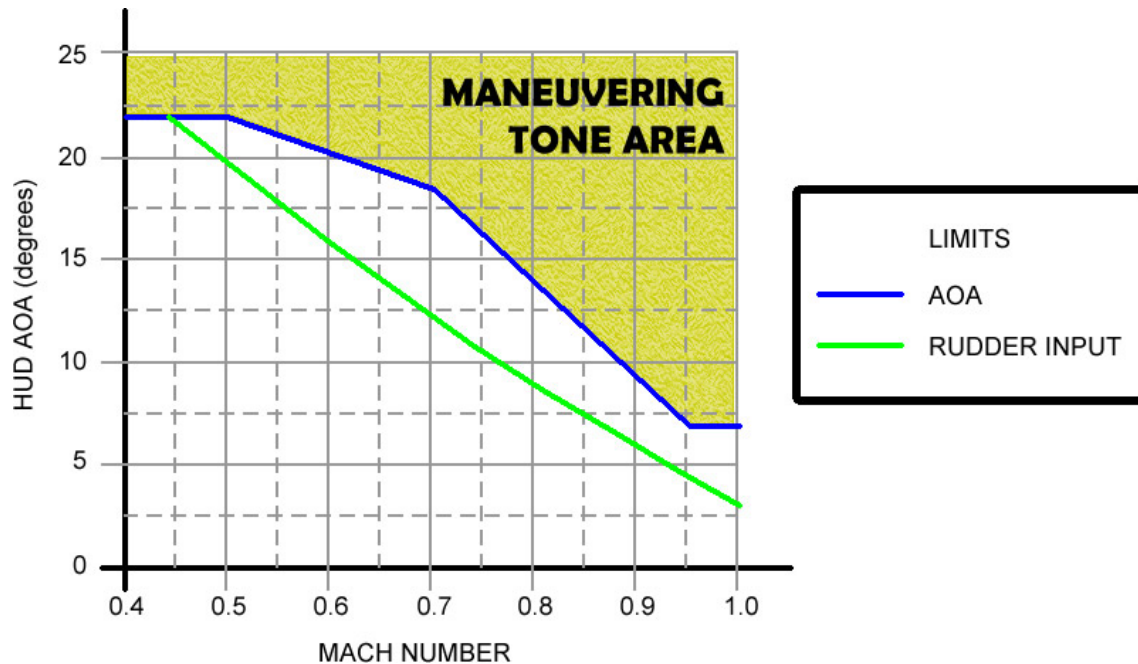

Prohibited Maneuvers

1. VTO with asymmetric load/stores greater than 45,000 inch-pounds.
2. STO with asymmetric load/stores greater than 85,000 inch-pounds.
3. CTO with asymmetric load/stores greater than 100,000 inch-pounds.
4. AUTO Flaps SL with asymmetric load/stores greater than 148,000 inch-pounds.
5. STOL Flaps SL with asymmetric load/stores greater than 85,000 inch-pounds.
6. VL with asymmetric load/stores greater than 80,000 inch-pounds.
7. Takeoff with less than 10° nozzles until wingborne.
8. Spin
9. Under 1g for more than 15 seconds.
10. Overriding aileron high speed stop.
11. Roll over 360°.
12. In accelerating or decelerating transition:
 - a. Over 15° AOA above 50 knots with landing gear down.
 - b. Between 30 to 100 knots, slideslip requiring more than ½ lateral stick or with RPS on.
13. Rearward or sideward translation above 30 knots.
14. Thrust Vector Control (TVC) above 30,000 feet at AOA above onset of stall warning/maneuvering tone or at less than 0g.
15. Flight above onset of stall warning/maneuvering tone with more than 60,000 inch-pounds asymmetry.
16. Abrupt simultaneous stabilator, rudder or aileron inputs with more than 90,000 inch-pounds asymmetry.
17. Wingborne flight at any speed with more than 148,000 inch-pounds asymmetry.
18. Flight above 0.88 Mach with more than 90,000 inch-pounds asymmetry. (see note)
19. Departure above 250 knots.
20. Rudder deflection above 0.80 Mach.

ATTENTION

For asymmetries above 90,000 inch-pounds, maneuvering limit is 5g, 10° AOA or stall warning, whichever occurs first.

Prohibited Maneuvers (SAAHS OFF)

1. Departure or stall.
2. Roll over 180° above 8° AOA.
3. Abrupt input of more the ½ rudder.
4. More than ½ lateral stick beyond onset of stall warning or with flap switch in CRUISE.

Weight Limitations

Maximum gross weight for taxi and takeoff is 32,000 pounds. Avoid abrupt maneuvering and hard braking at taxi gross weights above 29,750 pounds. Maximum gross weight for landing is 26,000 pounds.

Acceleration Limitations

1. The maximum permissible acceleration in the takeoff and landing configuration is 0.0g to 2.0g's.
2. The maximum permissible acceleration in smooth air with flaps in AUTO or CRUISE for an aircraft with empty pylons on only an air-to-air load is shown:

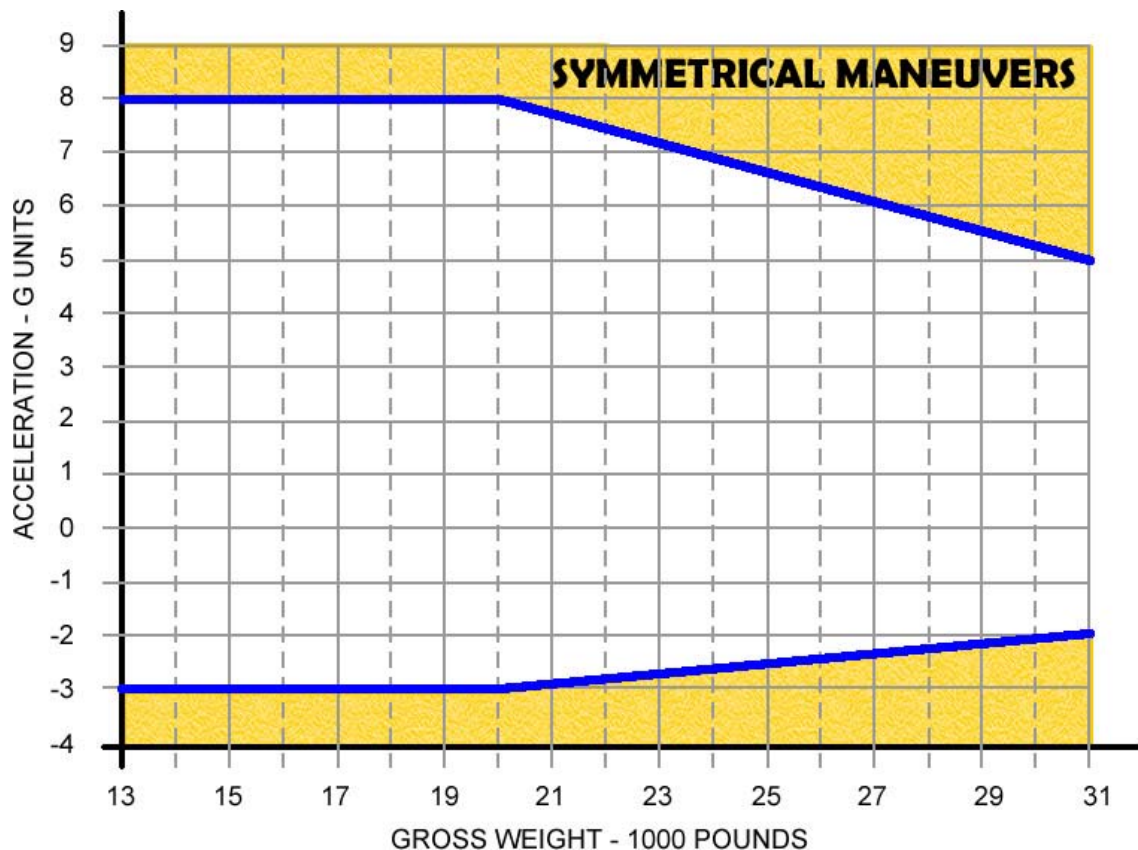

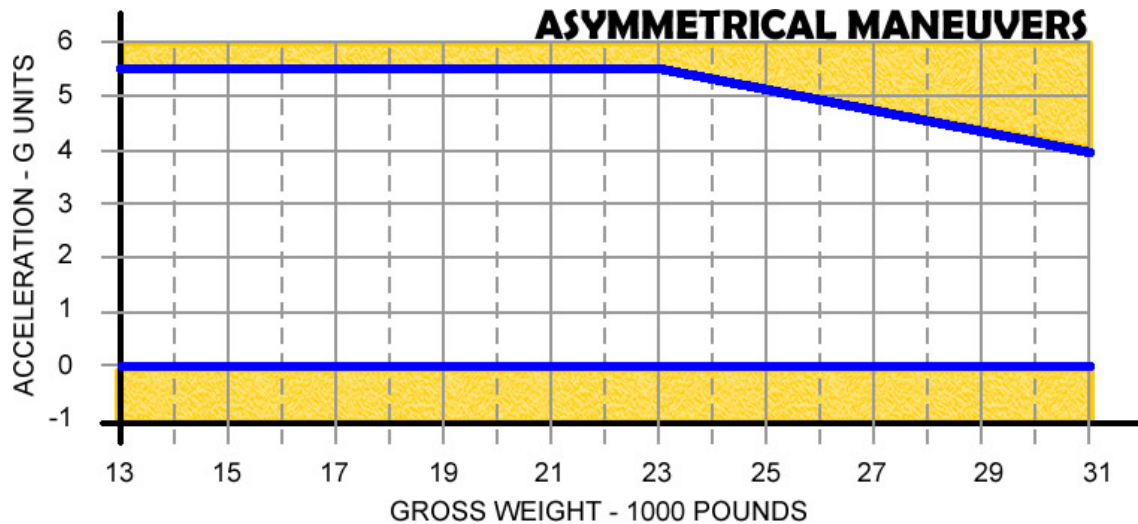

NOTE

Air-to-air load is two AIM-9 Sidewinders on pylons 1 and 7 and the GAU-12 gunpod.

Crosswinds Limitations

Paved runway (minimum width 100 feet).

Takeoffs

1. CTO (day or night): 20 knots
2. STO > 120 knots (day or night): 15 knots.
3. STO ≤ 120 knots (day or night): 10 knots.
4. RVTO
 - a. Day: 10 knots.
 - b. Night: 5 Knots.
5. VTO (day or night): 10 knots.

Landings

1. Approach speeds ≥ 140 knots.
 - a. Day: 20 knots.
 - b. Night: 15 knots.
2. Approach speeds < 140 knots.
 - a. Day: 15 knots.
 - b. Night: 10 knots.
3. Gross weight > 19,550 pounds, all approach speeds (day or night): 10 knots.

Systems Limitations

All Weather Landing System (ALWS)

Use of AWLS is limited to weather minimum of 400 foot ceiling and 1 nm visibility.

Automatic Flight Controls (AFC)

1. Use of basic attitude hold mode above 0.85 Mach is prohibited.
2. Use of altitude hold (ALT) below 500 feet AGL is prohibited.
3. Use of control stick steering in pitch with ALT engaged is prohibited.

Canopy

1. Canopy open with wind over 40 knots is prohibited.
2. Canopy open with RPM over 70% is prohibited.

Nozzle/Flap Limitations

During normal in-flight operations, with the exception of air refueling, use of STOL flaps is limited to nozzle positions greater than 25°.

WARNING/CAUTION/ADVISORY LIGHTS AND TONES

The warning/caution/advisory lights and displays system provides visual indications of normal aircraft operation and system malfunctions affecting safe operation of the aircraft. The lights are on various system instruments and control panel in the cockpit.

Master Warning Lights

The Master Warning lights consist of eleven green warning lights located to the right of the UFC panel and below the red MASTER WARNING light. They indicate a hazardous condition that requires immediate action:

- **FIRE:** Fire in the engine compartment.
- **LAW:** Low Altitude Warning: Below the minimum set altitude.
- **FLAPS:** Flap system failure.
- **L TANK:** Left fuel tank system overpressure or overtemperature.
- **R TANK:** Right fuel tank system overpressure or overtemperature.
- **HYD:** Both HYD1 and HYD2 systems have failed.
- **GEAR:** Landing Gear Unsafe/Fails to Extend.
- **OT:** (Overtemp) Engine JPT limits exceeded.
- **JPTL:** JPTL control inoperative. (Computer engine temperature control is malfunctioning).
- **EFC:** All Engine digital control boxes (DECU 1 and DECU 2) have failed. (Engine and fuel control reverts to manual mode).
- **GEN:** AC generator is offline.

Master Caution Lights

The Master Caution Lights consist of six green priority caution lights located to the left of the UFC panel and below the yellow MASTER CAUTION light. They indicate the existence of an impending dangerous condition requiring attention but not necessarily immediate action. Illumination of a priority caution light may require immediate corrective action in certain flight conditions.

- **L FUEL:** Left fuel system level is low.
 - Steady light: fuel level is less than 750 pounds.
 - Flashing lights: fuel level is less than 250 pounds.
- **R FUEL:** Right fuel system level is low
 - Steady light: fuel level is less than 750 pounds.
 - Flashing lights: fuel level is less than 250 pounds.
- **15 SEC:** JPT above normal lift rating (flashes after 15 seconds).
- **MFS:** Manual fuel system on.
- **BINGO:** Fuel below bingo setting.
- **H20:** Less than 15 seconds water remaining.

Caution/Advisory Lights

The green caution and advisory lights are located on the caution/advisory lights panel located in front of the right instruments panel.

Caution Lights

All caution lights indicate the existence of impending dangerous conditions that require attention but no necessarily immediate action.

- **AFC:** AFC malfunction or AFC deselected.
- **AFT BAY:** Aft avionics bay ECS failed.
- **APU GEN:** APU selected and emergency generator failed.

- **AUT FLP:** Auto flap mode or ADC failed.
- **CANOPY:** Canopy not closed and locked.
- **CASTER:** Not used on Night Attack. Illuminates on light test only.
- **C•AUT:** Computed delivery mode (AUTO and CCIP) not available.
- **CMBT:** Combat thrust activated. Flashes after 2 ½ minutes.
- **CS COOL:** Cockpit avionics cooling fan failed.
- **CW NOGO:** Jammer Failure. Cannot jam CW radars.
- **DC:** Main transformer-rectifier failed.
- **DEP RES:** Departure resistance reduced.
- **EFC:** DECU 1 or DECU 2 has failed.
- **ENG EXC:** Engine overspeed, overtemperature or over g was detected.
- **FLAPS 1:** Flaps 1 channel failed.
- **FLAPS 2:** Flaps 2 channel failed.
- **GPS:** GPS not valid.
- **H2O SEL:** Over 250 knots and water switch not OFF.
- **HYD 1:** HYD 1 pressure ≤ 1400 psi.
- **HYD 2:** HYD 2 pressure ≤ 1400 psi.
- **IFF:** Mod 4 off, not zeroized or not responding.
- **INS:** INS aligning or failed.
- **JMR HOT:** Jammer pod overtemp.
- **LIDS:** LIDS not in correct position
- **LOAD:** Fuel asymmetry over VL limit
- **NWS:** Nosewheel Steering malfunction.
- **OIL:** Oil pressure low.
- **OXY:** OBOGS malfunction.
- **PITCH:** Pitch stab aug off or failed.
- **P NOGO:** Jammer Failure. Cannot jam Pulse-Doppler radars.
- **PROP:** Fuel proportioner off or failed.
- **L PUMP:** Left fuel boost pump pressure low.
- **R PUMP:** Right fuel boost pump pressure low.
- **ROLL:** Roll stab aug off or failed.
- **SKID:** Anti-Skid System Malfunction.
- **STBY TRU:** Standby TRU inoperative or off line.
- **L TRANS:** Low air pressure to the left feeder tank.
- **R TRANS:** Low air pressure to the right feeder tank.
- **WSHLD:** Windshield hot.
- **YAW:** Yaw stab aug off or failed.

Advisory Lights

The green advisory lights indicate safe or normal configuration, condition or performance, operation of essential equipment or information for routine purposes. They are located on the caution/advisory lights panel and on various other panels throughout the cockpit.

- **NAV:** NAV HUD master mode selected.
- **VSTOL:** VSTOL HUD master mode selected
- **A/G:** Air-to-Ground HUD master mode selected
- **APU:** APU operating
- **CW JAM:** Jammer Pod Active: Jamming CW radar signals.
- **DROOP:** Ailerons dropped

- **P JAM:** Jammer Pod Active: Jamming Pulse-Doppler radar signals.
- **REPLY:** IFF responding to Mode 4 interrogation.
- **SEL:** Combat thrust limiter selected.
- **SPD BRK:** Gear up and speed brake extended. Gear down and speed brake not 25°.
- **STO:** Flap switch in STOL.

Threat Warning Lights

Threat warning lights indicate when the aircraft is under threat from enemy radars.

- **AAA:** Anti Aircraft Artillery gun radar is locked on aircraft.
- **AI:** Air Intercept radar is locked on aircraft. Flashes if launch detected.
- **CW:** Ground Tracking (Continuous Wave) radar is locked on aircraft.
- **SAM:** SAM launch detected.

Voice Warnings

Voice warnings, a.k.a. Bitching Betty, are provided in conjunction with certain warning/caution lights instead of special tones. All voice warning are presented twice: e.g. the voice warning associated with the FIRE warning light will be presented as ENGINE FIRE, ENGINE FIRE.

In the case of multiple voice warnings, the highest priority voice warning is sounded first. Before sounding the next voice warning, the priority list is checked to see if any higher priority warnings have become active.

VOICE WARNING AND ASSOCIATED WARNING/CAUTION LIGHTS			
VOICE WARNING	PRIORITY NUMBER	WARNING LIGHT	CAUTION LIGHT
ENGINE FIRE	1	FIRE	
OVERTEMP	2	OT	
HYDRAULICS	3	HYD	
FUEL CONTROL	4	EFC	
FLAP FAILURE	5	FLAPS	
LANDING GEAR	6	GEAR	
ALTITUDE	7	LAW	
LEFT TANK	8	LTANK	
RIGHT TANK	8	RTANK	
FIFTEEN SECONDS	9		15 SEC
BINGO	10		BINGO
LIMITER OFF	11	JTPL	
OBSTACLE	12		
WATER	13		H2O
FUEL LOW LEFT	14		L FUEL
FUEL LOW RIGHT	14		R FUEL
GENERATOR	15	GEN	
MANUAL FUEL	16		MFS
CAUTION	17		MASTER CAUTION
ACNIP GO			
ACNIP FAIL			

Voice warnings are not available on initial Early Release. They will be enabled on subsequent updates.

MASTER OPERATIONAL MODES

The AV-8B Night Attack weapons system is built around four master operational modes: navigation (NAV), vertical and short takeoff and landing (VSTOL), air-to-ground (A/G) and air-to-air (A/A). The master mode configures the aircraft avionics for navigation, landing and takeoff, or attack.

The NAV, VSTOL and A/G master modes can be selected by pressing the appropriate pushbutton in the MASTER MODE panel. The pushbutton illuminates when selected. The A/A mode is can only be selected by actuating the three-position A/A weapon select switch on the control stick.

The master modes are mutually exclusive with the last selected mode being the current mode of operations. At power up, the system initializes to the V/STOL mode. Master modes are deselected by selecting another master mode.

NAV

The NAV master mode is used for aircraft navigation. The NAV mode can be selected by clicking on the NAV pushbutton in the MASTER MODE panel.

In the navigation mode, primary flight information is presented on the HUD and aircraft horizontal situation is provided in the EHSD display in the MPCD.

Three navigation steering modes are provided and selectable from the EHSD display:

1. Waypoint, mark or waypoint/mark offset steering. It provides great circle steering to a selected waypoint, mark or waypoint/mark offset.
2. TACAN or TACAN offset steering. It provides great circle steering to a selected TACAN station or TACAN offset.
3. AWLS steering. It provides localizer and glideslope steering to a selected AWLS/ILS ground station.

VSTOL

The VSTOL master mode is a special mode used for takeoffs and landings. The VSTOL mode can be selected by clicking on the VSTOL pushbutton in the MASTER MODE panel.

With VSTOL selected, two options are displayed on the ODU: NRAS (nozzle rotation airspeed) and PC (pitch carets).

All basic navigation symbology is present in the HUD along with additional symbology including:

- Nozzle position (degrees)
- Flaps position (degrees)
- Engine RPM (percent)
- Engine Jet Pipe Temperature (degrees Celsius)

A/G

The A/G master mode is used to configure the aircraft for air-to-ground attack mode. The A/G mode can be selected by:

- Clicking on the A/G pushbutton in the MASTER MODE panel.
- Selecting waypoint overfly (WOF) or target-of-opportunity (TOO) modes in the UFC.

Activation of the A/G master mode initializes the selected weapon and weapon program for delivery and provides attack symbology on the HUD.

A/A

The A/A/ master mode is automatically entered by selecting an air-to-air weapon via the A/A weapon select switch on the control switch. The following are the A/A weapons selection available:

- Switch Forward: Sidewinder in Boresight mode
- Switch Aft: Sidewinder in expanded acquisition mode (SEAM)
- Switch Down: Sets the GAU-12 to air-to-air mode. Subsequent actuations toggle between long and short range gunsight.

Selection of any of these weapons activates the weapon's associated A/A aiming symbology on the HUD.

THE HEAD-UP DISPLAY (HUD)

The head-up display (HUD) is on the top of the main instruments panel. The HUD is the primary flight control, weapon status and weapon delivery display for the aircraft under all selected conditions. The HUD receives attack, navigation, situation and steering control information and projects symbology on the combining glass for head-up viewing. Symbology is unique to the master mode selected.

HUD symbology can also be presented head-down on the MPCDs by clicking on the HUD menu option (PB5) when the MPCD main menu is displayed.

The HUD can display FLIR video in all master modes provided that the HUD symbology brightness selector switch is in the NIGHT position.

The controls for the HUD are below the UFC.

HUD CONTROL PANEL

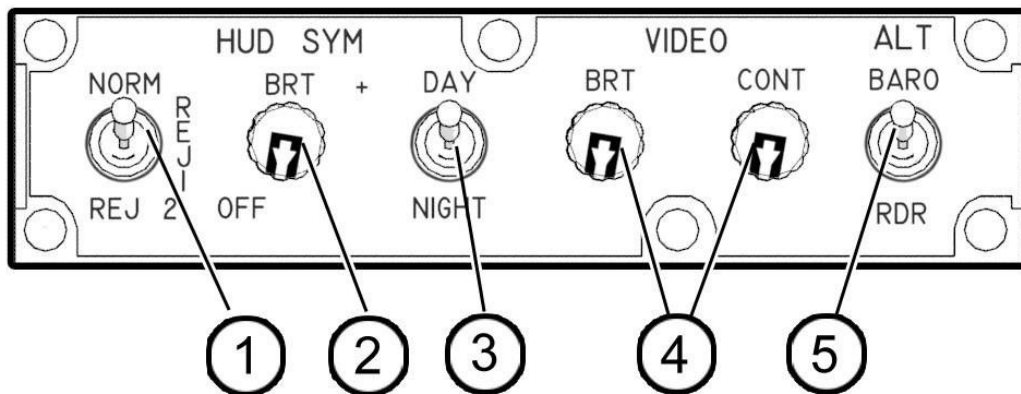

1. HUD Symbology Reject Switch.
This three-position switch controls the amount of symbology provided for all HUD displays. See HUD Basic Symbology for more information on reject modes.
2. HUD Symbology Brightness Control.
This knob is used to turn on the HUD and the varies the symbology display intensity.
3. HUD Symbology Brightness Selector Switch.
This switch in conjunction with the HUD symbology brightness control selects symbol brightness. The NIGHT position must be selected to have FLIR video on the HUD.
4. FLIR Video Controls.
These knobs control FLIR video brightness and contrast on the HUD. The BRT control has a pushbutton feature that allows that swaps the displays on the MPCD when clicked.
5. Altitude Switch.
This is a two-position toggle switch. This switch is used to select either radar altitude(RDR) or barometric altitude (BARO) for display on the HUD.

NOTE

The following controls are not available on initial Early Access release: HUD Symbology Brightness, FLIR Video Controls, MPCD display swap. These controls will be available on subsequent updates.

HUD BASIC SYMBOLOGY

NAV

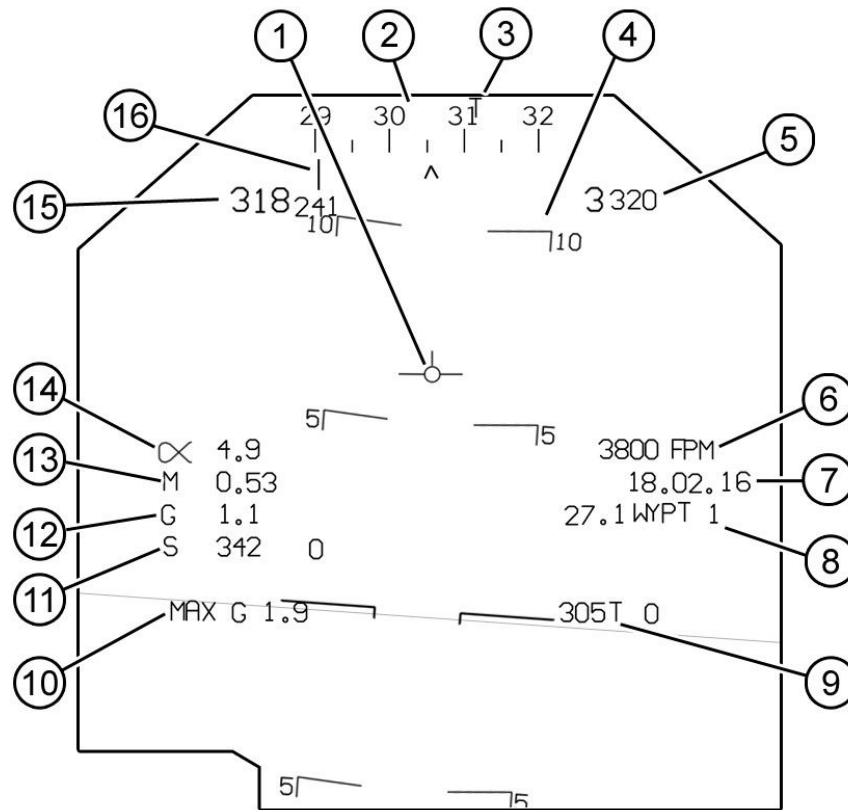

1. Velocity Vector Marker (VVM)
2. Heading Scale
3. True Heading Marker (only visible when true heading is selected).
4. Pitch Ladder
5. Indicated Altitude (Barometric selected)
6. Vertical Velocity in feet per minute (FPM)
7. Clock (Zulu time selected).
8. Current waypoint data: Distance (NM) + Waypoint number.
9. Auxiliary heading indicator (T is shown when True heading is used).
10. Max Gs attained.
11. Ground Speed (Knots)
12. Current Gs.
13. Mach number.
14. Angle of Attack (AOA)
15. Indicated Speed (Knots)
16. Bearing to Waypoint.

Reject level 1 removes AOA, FPM. Adds AOA and FPM analog scales.

Reject level 2 removes AOA, FPM, Mach, Current Gs and Ground Speed. Adds AOA and FPM analog scales.

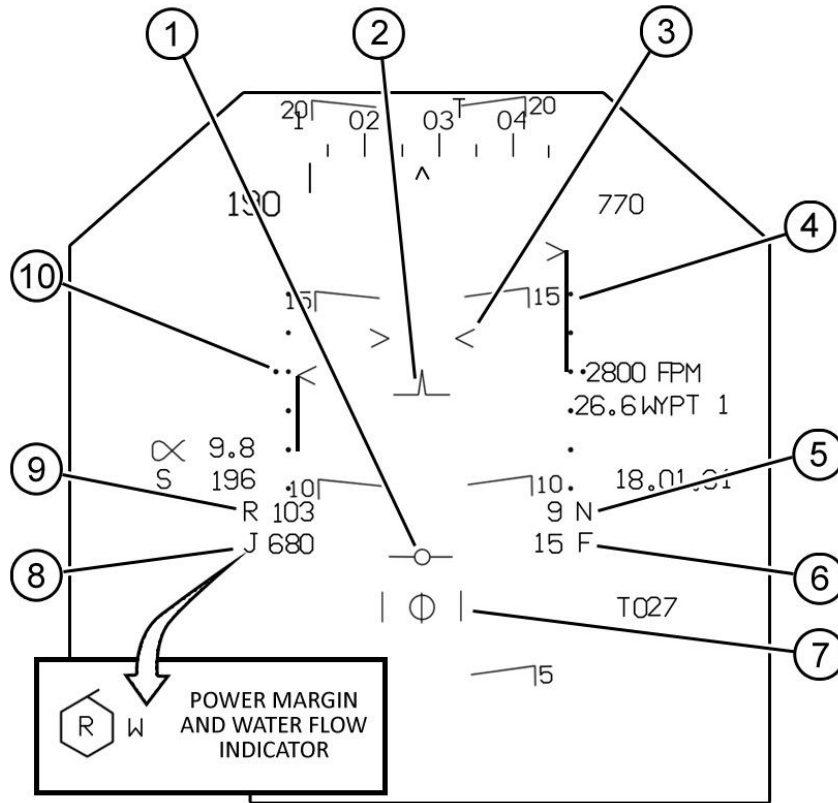

















1. Vertical Flight Path Symbol (VFP)
2. Depressed Attitude Symbol (Witch Hat).
3. Pitch Carets (PC)
4. Vertical Speed Analog Scale.
5. Digital Nozzle Position Indicator. (N)
6. Digital Flap Position Indicator. (F)
7. Slideslip Indicator.
8. Digital Jet Pipe Temperature (JPT) in Celsius.
9. Digital RPM (percent).
10. Angle of Attack Analog Scale.

- **The Power Margin Indicator** replaces JPT and RPM when threshold is reached (see threshold table below).
- **The Water Flow Indicator** appears when the Water switch is in either TO or LDG and the water is flowing into the engine.

Reject level 1 removes AOA, FPM and Power Margin Indicator (if displayed) (JPT and RPM are displayed).

Reject level 2 removes AOA, FPM, N, F, JPT, RPM and Power Margin Indicator if displayed.

Power Margins for F402-RR-408 Engine

RPM - %			JPT – °C		
	DRY	WET		DRY	WET
	107.0	113.5		715	735
	108.0	114.5		725	745
	109.0	115.5		735	755
	110.0	116.5		745	765
	111.0	117.5		755	775
	112.0	118.5		765	785
	113.0	119.5		775	795
	113.5	120.0		780	800

The threshold reached first determines whether R or J power margin is displayed. If RPM or JPT is still increasing after completing the hexagon, the last leg of the hexagon continues in a straight line. The length of the line is proportional to the increase in RPM or JPT.

ATTACK (A/A and A/G)

For HUD attack symbology please refer to the **Weapons Acquisition & Delivery Modes** section.

NOTE

In A/G Attack mode the HUD will display True Airspeed instead of Indicated Airspeed. True Airspeed is displayed because it is the speed used by the targeting system for weapons delivery computations.

THE UPFRONT CONTROL (UFC) & OPTION DISPLAY UNIT (ODU)

The Upfront Control (UFC)'s pushbuttons and indicators are used for entering (ENT) or clearing (CLR) data. It is also the main communications controller.

The UFC consists of a LCD screen, which works both as a display and as a scratchpad when entering data, function mode keys that are used to determine operational mode, special input keys and a numeric keypad.

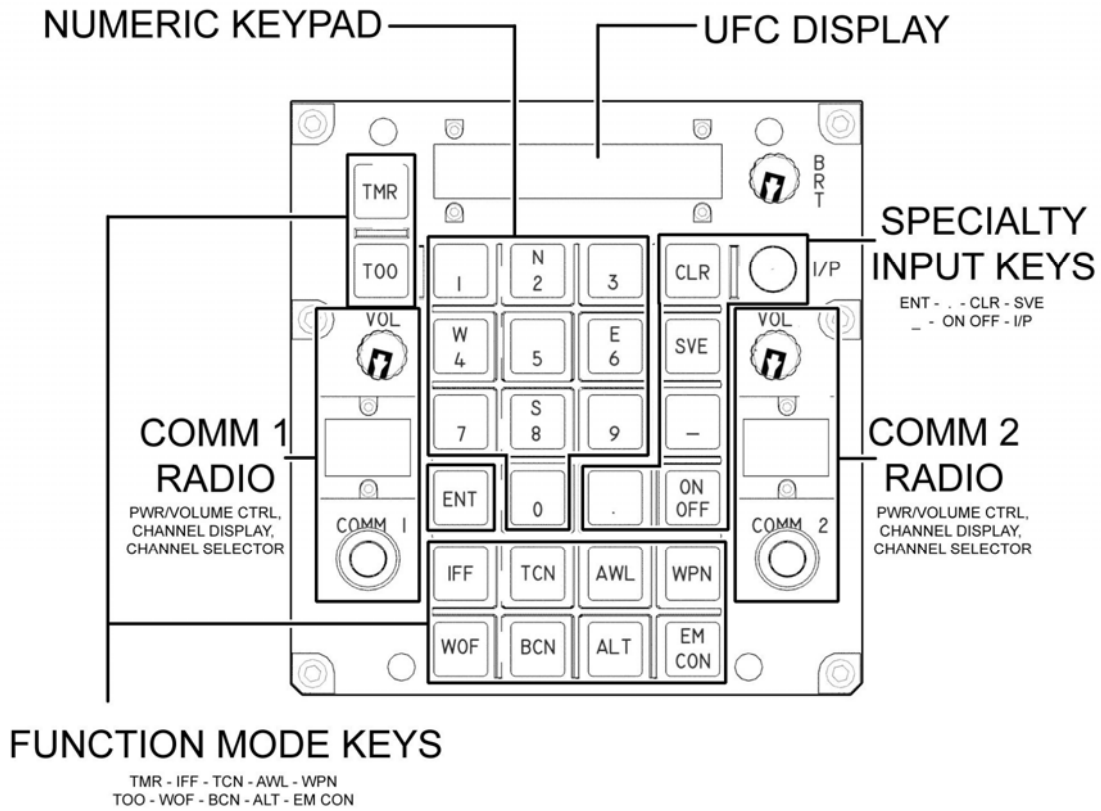

The Option Display Unit (ODU) consists of 5 LCD screens with a pushbutton on each (OB1 to OB5). The ODU is used to display and select the data options (one option per screen) available for a specific UFC function mode. Selecting an option either enables/disables it or sets the UFC for data entry.

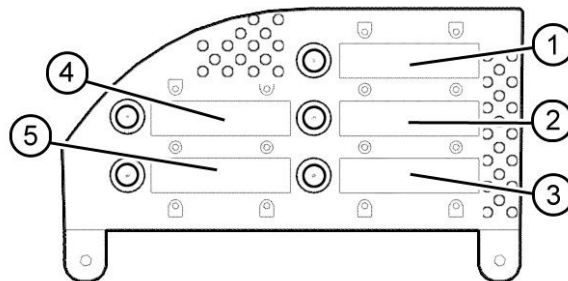

To enter/edit a UFC value, you first have to select it by using the respective ODU pushbutton. The selected value will be displayed in the UFC scratchpad. To change it all you have to do is enter the new value by clicking on the numeric keyboard and then clicking either enter (ENT) to save the new value or clear (CLR) if the value is erroneous.

Special Input Keys

Editing Keys



ENTER: It validates entered values and save them.



CLEAR: Clears all entered values without validating nor saving them.



SAVE: Not used.

Action Keys



ON/OFF Toggle: Used to activate/deactivate the selected function and/or device.



Identification-of-Position: Used by the IFF to send an ID pulse when in modes 1, 2 and 3/A.

FUNCTIONALITY NOT MODELLED.

Data Modifiers Keys



Decimal Point: Used to enter a decimal point. Any value entered after this key has been pressed will be considered a decimal.



Negative: Used to convert entered values into their negative. If the value is positive, it is converted into a negative; and vice versa.

UFC MODES & FUNCTIONS

The UFC has several modes allowing to interact with all the aircraft's functions.

The UFC modes can be selected either by clicking on the function mode key in the UFC or by interacting with the Master Mode pushbuttons or the MPCD pushbuttons on certain pages.



IFF: Sets the UFC for configuring the Identification Friend or Foe system. (See IDENTIFICATION for a description of this mode).



TACAN: Sets the UFC for configuring the TACAN. Receiver. (See NAVIGATION for a description of this mode).



All Weather Landing System: Sets the UFC for configuring Instruments only landing system (AWL/ILS). (See NAVIGATION for a description of this mode).



WEAPONS: Sets the UFC for weapons delivery programming. (See WEAPONS MANAGEMENT for a description of this mode).

WOF

Waypoint Over Fly: Used for INS position update.
(See NAVIGATION for a description of this function).

BCN

RADAR Beacon: Activates/Deactivates the RADAR beacon identification system.
(See IDENTIFICATION for a description of this function).

ALT

Altimeter: Sets the UFC to configure the aircraft's altimeters.
(See WEAPONS MANAGEMENT for a description of this mode).

EM
CON

Emission Control: Activates/Deactivate the Emission Control system.
(See COMMUNICATIONS for a description of this function).

TMR

Timer: Sets the UFC for configuring all systems clocks.
(See WEAPONS MANAGEMENT for a description of this mode).

TOO

Target-Of-Opportunity: Sets a specific spot on the ground as a target.
(See WEAPONS MANAGEMENT for a description of this function).

V/STOL: Sets the UFC for configuring Takeoff and Landing parameters. The UFC enters in this mode when the VSTOL master mode button is clicked.

LASER Code: Sets the UFC for configuring the Code for the Laser Spot Tracker and the Laser Spot Designator (if the TPOD is loaded). The UFC enters in this mode when the option is selected in either the STRS or DMT page in the MPCD.

COM1 & COM2: Sets the UFC for configuring radio communications. The UFC enters this mode when the Radio Channel Selector is either turned or pressed. The selected radio depends on which selector is actuated. COM1 for Radio 1 and COM2 for Radio 2.

ATTENTION

Once a function mode is selected the UFC will wait for 30 seconds for any keyboard input. If no input is detected it will deselect the function and go into standby mode by clearing both the UFC and ODU's displays.

NOTE

On initial Early Access release, only the following UFC functions/modes are available: TCN, AWL, V/STOL, LASER Code, COM1 & COM2. The remaining functions/modes will be activated in subsequent updates.

THE MULTI-PURPOSE COLOR DISPLAYS (MPCD)

The multipurpose color display (MPCD) on either side of the main instrument panel are the primary aircraft head down display. They consist of a 5 by 5 inch CRT display surrounded by 20 multi-function buttons (PB1 thru PB20). MPCD mode selection is accomplished either automatically, as determined by the mission computer, or manually as selected by the pilot on the MPCD or by HOTAS.

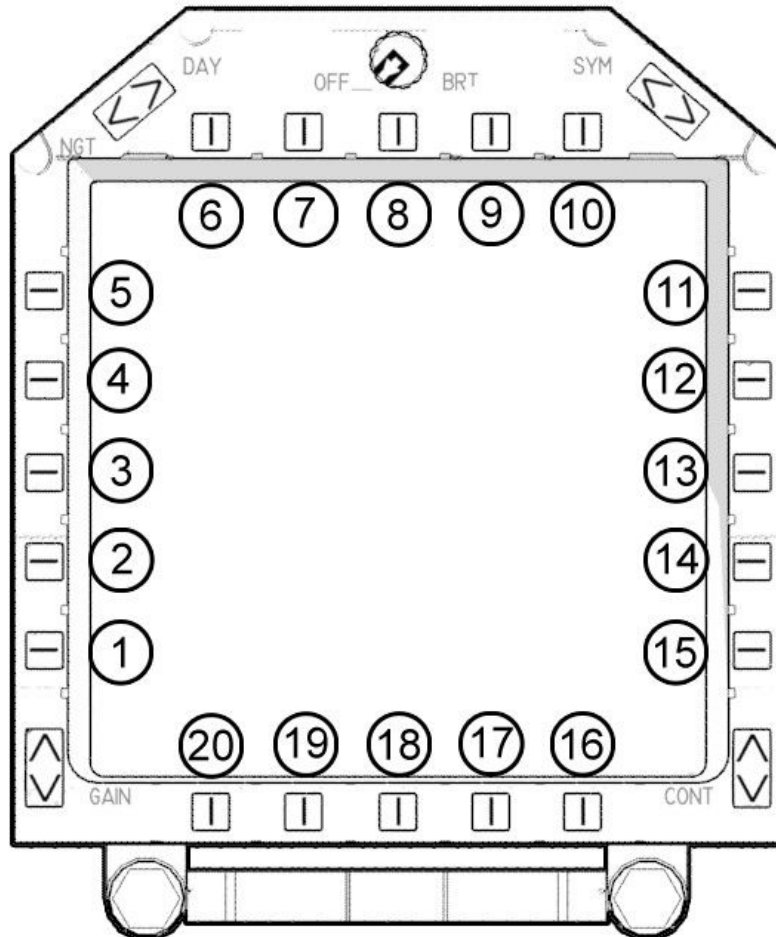

The following buttons have the same functionality on all pages:

Button 15: Displays the EW page. The only exception is on the TPOD page, where it is used to toggle the LITENING POD to/from standby mode.

Button 18: Always returns to the Main Menu. The only exception is in the Main Menu, where it is used to display the Emergency Checklist cards.

The MPCD can be turned ON/OFF by clicking on the OFF/BRT knob. Brightness control is not available on Early Access.

Main Menu Options

The displays options are the following (in button order):

1. FLIR: It displays the NAVFLIR image on the screen.
2. EHSD: Electronic Horizontal Situation Display
3. DMT: Dual Mode Tracker. It displays the DMT video on the screen.
4. STRS: Stores Page. It displays the aircraft's stores load. It allows weapons selection.
5. HUD: HUD repeater. It displays the HUD symbology. It can also display NAVFLIR video.

6. BIT: Built-In Test page for all aircraft's systems.
7. **Blank**
8. VRST: VSTOL – REST calculator page.
9. **Blank**
10. **Blank**
11. ENG: Engine Parameters page.
12. CONF: Software Configuration page.
13. TPOD: LITENING II Pod Page. This option is **blank** if the TPOD is not loaded.
14. IFF: IFF Data page.
15. EW: Electronic Countermeasures/Warfare page. It displays the RWR.
16. CARD: Pre-programmed kneeboard card display page.
17. CAS: Close Air Support page.
18. EMER: Emergency Checklist Cards page.
19. SDAT: System Data page.
20. COMM: Communication data page.

NOTE

In the initial Early Release version only the following pages are available: FLIR, EHSD, DMT, STRS, ENG, TPOD and EW. All other pages will become available on subsequent updates.

FLIGHT INSTRUMENTS

Please refer to the Main Instruments Panel guide to see where the flight instruments are located. The instruments are described in this section. Unless otherwise specified all these instruments do not require electrical power.

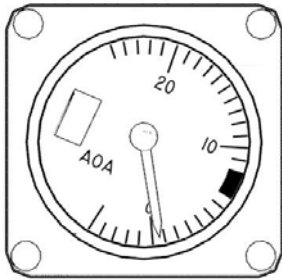

Standby Angle of Attack Indicator

The standby AOA indicator is calibrated from -5° to $+25^{\circ}$. AN OFF flag appears when electrical power is interrupted.



Standby Vertical Velocity Indicator.

The standby VVI displays rate of ascent or descent on a scale from 0 to 6,000 feet per minute.

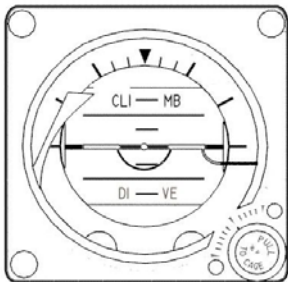

Standby Attitude Indicator.

The standby attitude indicator is a self-contained gyro-horizon type of instrument. AN OFF flag appears whenever electrical power is lost or the unit is caged.



Standby Altimeter.

The standby altimeter displays altitude from -1,000 feet to 50,000 feet. The counter drums indicate altitude in thousands of feet from 00 to 99. The needle indicates altitude in 50 foot increments with one full revolution each 1,000 feet. A knob and window permit setting the altimeter to the desired barometric setting. This setting is also used by the Air Data Computer (ADC).

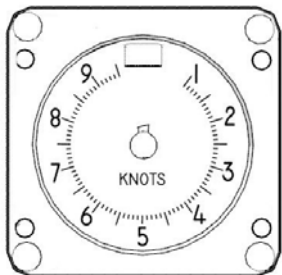

Standby Airspeed Indicator

The standby airspeed indicator displays airspeeds from 20 to 600 knots. The indicator contains two needles and a single scale graduated from 1 to 10. The needles appear one at a time. At low airspeeds, the scale represents 0 to 100 knots and the thin needle indicates the airspeed. At higher airspeeds, the scale represents 100 to 1,000 knots and the thick needle indicates the airspeed. However, the thick needle will not proceed beyond the 600 knots indication.

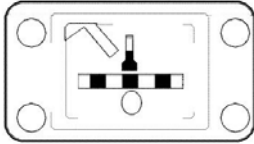

Turn and Slip Indicator

The turn and slip indicator consists of a scale, turn pointer, power warning flag and inclinometer ball.

A 2-minute turn is indicated with the needle over the index to the left and right of center.

A 4-minute turn is indicated with the needle fall way between the center and the right or left index.

The OFF flag is visible when the instrument loses power.



Standby Magnetic Compass

A conventional aircraft magnetic compass is installed on the canopy left frame.

NAVIGATION

The Inertial Navigation System (INS)

The inertial navigation system (INS) is a self-contained, fully automatic dead reckoning navigation system. The INS detects aircraft motion and provides acceleration, velocity, present position, pitch, roll and true heading to related systems.

INS Controls and Indicators

The controls and indicators for the INS include the ODU, UFC, MPCD and Miscellaneous switch panel. The miscellaneous switch panel contains the INS mode selector switch which selects the following modes of INS operation:

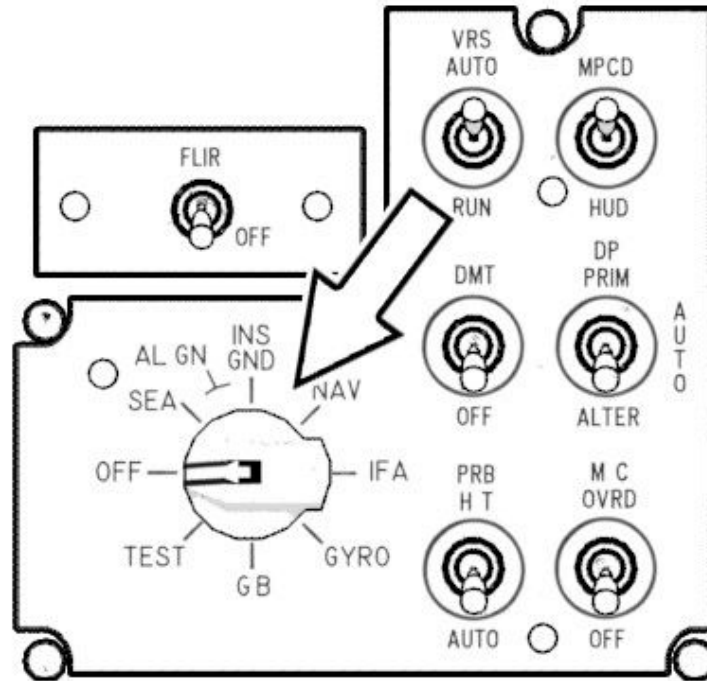

- | | |
|-------------|--|
| OFF | Power is removed from the INS. |
| SEA | Selects INS sea align mode. It connects with a ship inertial navigation system SINS to perform an INS alignment. It provides a sea alignment display on the MPCD provided the parking brake is on. |
| GND | Selects INS ground align mode. It performs a ground alignment and provides an alignment display on the MPCD provided the parking brake is on. |
| NAV | Selects INS navigation mode and provides navigation steering information. |
| IFA | It initiates an IN-FLIGHT ALIGNMENT and causes the INS to be coupled with the GPS. |
| GYRO | Emergency mode. On the ground or aboard a ship it provides attitude and true heading. In flight, it only provides attitude. |

GB	Not used
TEST	Selects the test mode. INS can be commanded to initiate a BIT.

NOTE

In the initial Early Release version, the INS will always be pre-aligned.
Alignment options are not available until further notice.

The TACAN (Tactical Air Navigation) System

The TACAN system gives precise bearing and/or slant range distance to a TACAN ground station or suitable equipped aircraft. The TACAN system is limited to line-of-sight (LOS) range which depends upon aircraft altitude. The maximum operating range is 390 nautical miles (NM) when the selected TACAN station is a surface beacon and 200 NM when the selected station is an airborne beacon.

TACAN Controls and Indicators

The controls and indicators for TACAN operation are on the UFC, ODU and MPCD.

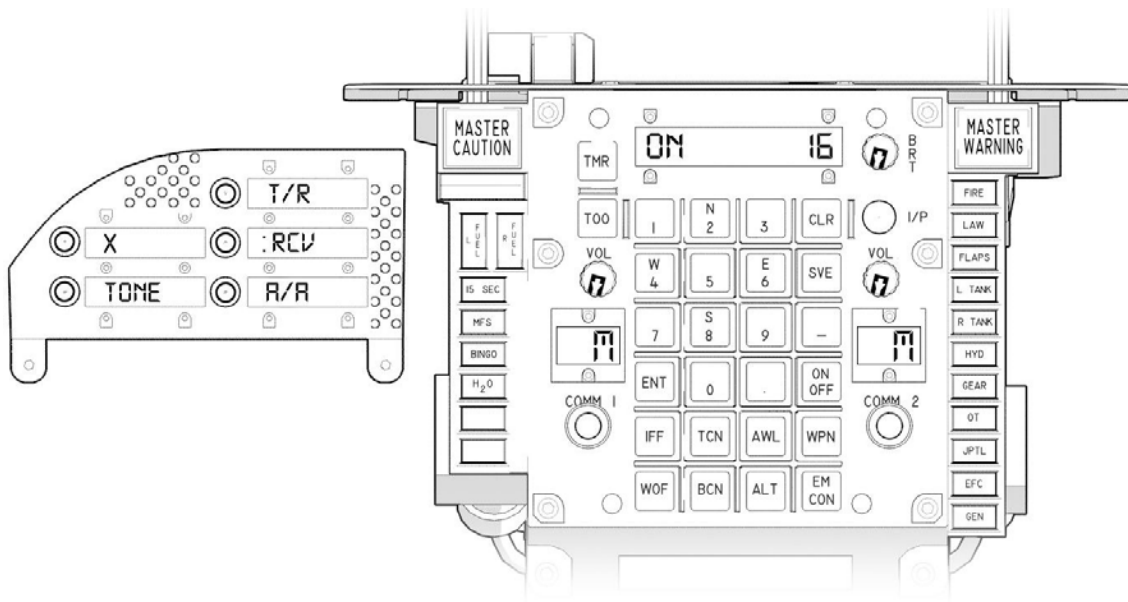

UFC and ODU in TACAN Mode

UFC

The pushbuttons and indicators that are used for TACAN operation and display are the TCN button, ON/OFF button, EMCON button, Numeric Keyboard and Scratchpad.

- **TCN Button:** Clicking on this button enables or disables the TACAN options in the UFC. When enabled the scratchpad will display current TACAN channel on the right side. On the left side, the ON label will be displayed if the TACAN system is active.

To change a TACAN channel click on the numeric pad and then click ENTER (ENT). In case you made a mistake, click the CLEAR (CLR) button and try again. The Decimal Point and Dash buttons will be ignored.

- **ON/OFF Button:** Clicking on this button activate/deactivate the TACAN system. The ON message will be displayed on the left side of the scratchpad when the system is active

- **EMCON Button:** Clicking on this button puts the TACAN system in a receive-only mode. Options 1 thru 5 are blanked in the ODU and then Option 1 displays :EMCN. The colon indicates that emission control is active. Clicking again on the EMCON button return to previous operating mode.

ODU

- **Option 1:** Selecting T/R option commands the TACAN receiver-transmitter to operate in that mode. A colon (:) is displayed to the left of the T/R legend (:T/R) to indicate that the mode has been selected. In T/R mode range and bearing to the selected TACAN ground station is provided to the EHSD and HUD.
- **Option 2:** Selecting the RCV option commands the TACAN receiver-transmitter to operate in air-to-ground receive mode. In RCV mode only bearing (not range) is provided by the ground station. The T/R and RCV are mutually exclusive. A colon (:) is displayed to the left of the RCV (:RCV) to indicate that the mode has been selected.
- **Option 3:** Selecting the A/A option commands the TACAN receiver-transmitter to operate in the air-to-air mode. In A/A mode bearing and range to a suitable equipped cooperating aircraft is displayed on the EHSD and HUD. Also, in A/A mode the TACAN transmits a distance replay to an interrogating aircraft. Deselecting A/A causes the TACAN to operate in air-to-ground mode.
- **Option 4:** Clicking this button selects either X or Y channel for TACAN operation. Successive clicking on the button alternates between the X and Y channels.
- **Option 5:** Clicking on the TONE button allows the TACAN identification tone to be turned on or off. A colon (:) appears on the left side of the option display window when the tone is enabled.

MPCD

The MPCD uses the EHSD main page to display TACAN data. If not selected then press PB18 to call the main menu and the select the EHSD (PB2) option.

Please refer to the **Electronic Horizontal Situation Display (EHSD)** for more information on the data displayed.

The All Weather Landing System (AWLS)

The AWLS provides the aircraft with steering information to fly a selected glideslope and localizer. AWLS steering provides situation steering display on the HUD, representing aircraft position to maintain the localizer and selected glideslope. AWLS steering bars are displayed when azimuth and elevation signals are valid. **The elevation steering bar will be displayed only when both elevation and azimuth signals are valid.** DME range is displayed when valid TACAN signals are present.

AWLS can only be engaged in the NAV and VSTOL master modes.

AWLS Channels.

The AWLS only works with preset information stored in a channel. The system can store up to 20 channels at a time. These must be set before the flight as there is no option allowing the pilot the ability to edit a given channel frequency.

The information stored for a given channel is the following:

Field Name	Field Data Type
Name	Text: The name of the airport or FOB
Runway	Text: The number of the associated runway
ILS_freq	Numeric: The station radio frequency in MHz
Tacan_ch	Numeric: The associated TACAN station channel (if it exists). 0 if it does not

Field Name	Field Data Type
Tacan_xymod	Numeric: 0 if the TACAN station uses X mode. 1 if it uses Y mode.
Ils_gs	Numeric: The glideslope used by the station. (default is 3.0)
Ils_az_os	Numeric: Runway +/- azimuth offset (in feet) to the station
Ils_el_os	Numeric: Runway +/- elevation offset (in feet) to the station

The presets are stored in the AN_ARN128_config.lua file, which can be found in the “<DCS main folder>\Mods\aircraft\AV8BNA\Cockpit\Scripts\RadioNav” folder.

AWLS Controls and Indicators.

The controls and indicators for the AWLS include: UFC, ODU, MPCD and HUD.

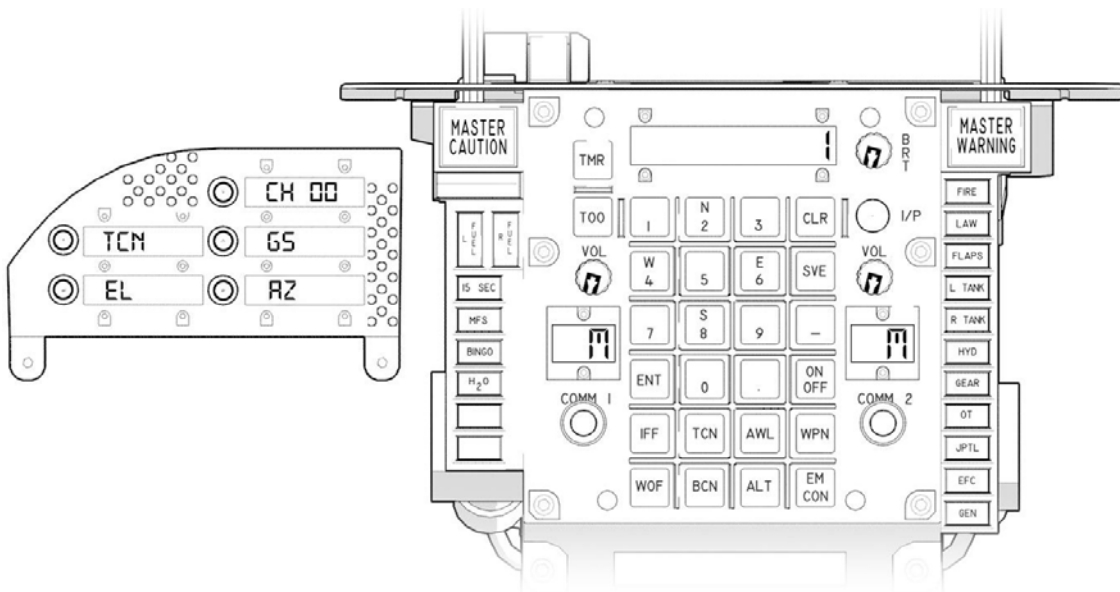

UFC and ODU in AWLS mode.

UFC

The pushbuttons and indicators that are used for AWLS operation and display are the AWL button, ON/OFF button, Numeric Keyboard and Scratchpad.

- **AWL Button:** Clicking on this button enables/disables the AWLS and displays the associated option in the ODU. The UFC will display the previously entered channel on the scratchpad.
- **ON/OFF Button:** Clicking on this button turns the AWLS on or off. Selection of the AWLS option in the EHSDI main page on the MPCD also turns on the system.

ODU

- **Option 1:** Displays the current AWLS channel (CH1 thru 20). If CH00 is displayed it means that no channel has been selected. Clicking on this option enables the UFC to display the channel number in the scratchpad and the UFC keyboard can be used to change the channel number.
- **Option 2:** Displays the letters GS. Clicking on this option displays the current glideslope on the UFC's scratchpad and allows the UFC's keyboard to be used for changing it. Glideslope value limits are from 2.0° to 6.0° with a resolution of 0.1°

- **Option 3:** Displays the letters AZ (azimuth). When the AZ option is selected, the UFC scratchpad displays the current runway azimuth offset for editing. Azimuth offsets up to +/- 310 foot in 1 foot increment can be entered. Negative numbers mean that the runway centerline is to the left of the ALWS station. Positive numbers mean that the centerline is to the right.
- **Option 4:** Displays the letter TCNX or TCNY. Clicking on this option toggles between these two values. The UFC scratchpad displays the associated TACAN channel for edition.
- **Option 5:** Displays the letters EL (elevation). Clicking on this option displays the runway elevation offset (in feet) on the UFC scratchpad for edition. Elevation offsets up to +/- 31 feet in 1 foot increments can be entered.

NOTE

Zero is a valid azimuth/elevation offset value. All offsets are automatically zeroed to their default values when a AWLS channel is changed.

MPCD

The MPCD uses the EHSD main page to display AWLS data. If not selected then press PB18 to call the main menu and then select the EHSD (PB2) option.

Please refer to the **Electronic Horizontal Situation Display (EHSD)** for more information on the data displayed.

On the EHSD display click on the AWLS button (PB4). The AWLS option will be boxed and the UFC/ODU will be set in AWLS mode. The AWLS will be turned on if it was off. Selection of AWLS also turns on the TACAN.

NOTE

The ALWS uses its own independent TACAN channel. When AWLS steering is activated, the AWLS will override the current TACAN channel. This TACAN channel is restored when AWLS steering is deselected.

HUD

When the AWLS beam is acquired, a vertical azimuth steering bar and a horizontal elevation steering bar are displayed. Both bars are referenced to the velocity vector in NAV mode and to the vertical flightpath in the VSTOL mode.

The azimuth bar represents aircraft azimuth angle from the localizer and the horizontal bar represents aircraft elevation angle from the glideslope. Full deflection of the steering bars on the HUD represent +/- 2° for elevation and +/- 6° for azimuth. Azimuth steering reference marks are provided adjacent to the velocity vector/vertical flightpath symbol when the AWLS steering mode is selected. The reference markers denote 3° and 6° steering deviation (left and right).

Glideslopes angles of less than 2° or more than 6° should not be used. The pilot must keep the elevation bar centered on the velocity vector to fly the selected glideslope.

The Electronic Horizontal Situation Display (EHSD)

The HESD is selected by clicking on the MPCD Button 2. It displays aircraft current position in relation to waypoints and radio navigation stations like TACAN or ALWS. It also displays data about waypoint and TACAN stations and a digital map.

It is the main navigation display and can be used for target designation and weapons selection when the system is in A/G mode.

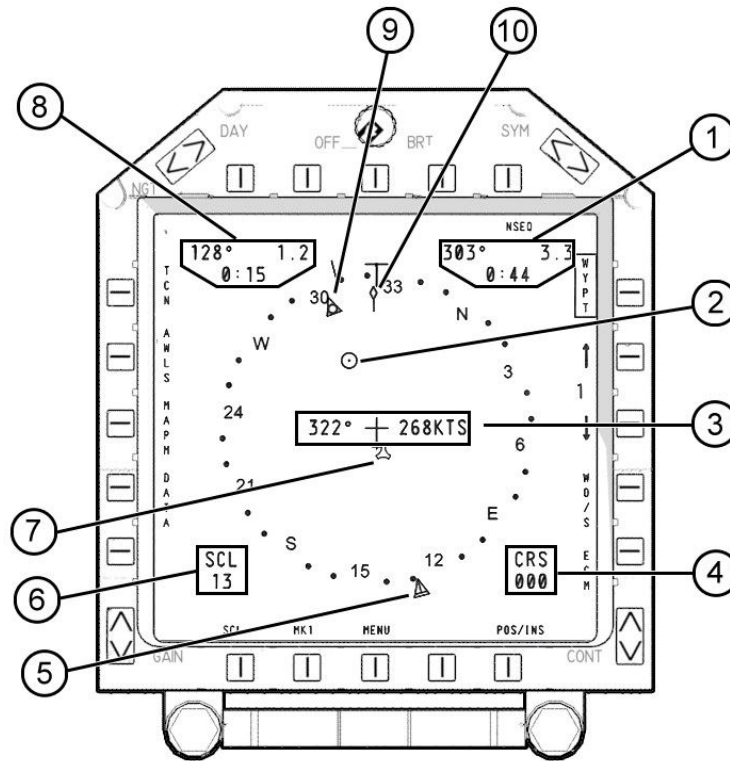

EHSD Main Page (Typical NAV/VSTOL mode)

1. Waypoint Data: Bearing (degrees), Distance (NM), Time-to-Go to waypoint (minutes:seconds).
2. Waypoint Polar Position relative to aircraft (range and bearing). Only displayed if within range scale.
3. Aircraft Data: Ground Track (degrees), Ground Speed (Knots).
4. Selected Course.
5. TACAN Bearing Pointer.
6. EHSD Map Scale.
7. TACAN Polar Position relative to aircraft (range and bearing). Only displayed if within range scale.
8. TACAN Data: Bearing(degrees), Distance (NM) and Time-to-Go to TACAN station (minutes:seconds).
9. Waypoint Bearing Pointer.
10. Aircraft Ground Track Pointer.

Flight Plan

The INS can store one flight plan at a time consisting of up to 25 waypoints, their associated offset points and 3 mark (MK) points.

NOTE

In the Early Release version, the pilot can only navigate through a flight plan created in the Mission Editor. The ability to create and modify flight plans in-cockpit will be introduced in subsequent updates.

MK navigation is not enabled until future updates.

Steering Modes

The INS provides three main steering modes. Waypoint, TACAN and ALWS. To select any steering mode the pilot must click on the respective MPCD pushbutton on the EHSD main page. The selected steering mode will be boxed.

All steering modes are mutually exclusive with the last selected mode being the current steering mode. At power up, the system initializes to the WAYPOINT steering mode. Steering modes are deselected by selecting another steering mode.

Waypoint

Waypoint steering allows the pilot to follow the stored flight plan. To select Waypoint steering click on the WYPT button (PB11) in the EHSD Main Page. The WYPT option is boxed, indicating that the Waypoint steering mode is engaged.

The pilot can change the current waypoint by clicking on the UP (PB12) or DOWN (PB13) arrows. The number between the arrows indicate current waypoint and will change accordingly.

NOTE

It is not possible to select the starting point (Waypoint 0). To fly a route back to the starting point, it must be included as a waypoint in the flight plan.

TACAN

TACAN steering allows the pilot to fly a selected course to or from a TACAN station. To select TACAN steering click on the TCN button (PB5) in the EHSD Main Page. The TCN option is boxed, indicating that the TACAN steering mode is engaged.

Clicking on the TCN button also turns on the TACAN system if not on.

Please refer to the **TACAN system** chapter for more information on the TACAN.

AWLS

AWLS steering allows the pilot to fly a localizer and glideslope path to the selected runway. To select AWLS steering click on the AWLS button (PB4) in the EHSD Main Page. The AWLS option is boxed, indicating that the AWLS steering mode is engaged.

Certain options in the EHSD main page will be disabled while in AWLS steering mode.

Clicking on the AWLS button also turns on both the AWLS and the TACAN if they were off.

AWLS steering can only be selected while the aircraft is in either NAV or VSTOL master mode.

Please refer to the **AWLS** chapter for more information on the AWLS.

COMMUNICATIONS

V/UHF Radios

The V/UHF communication system provides air-to-air and air-to-ground communication over dual UHF/VHF radios. The system utilizes two ARC-210 radio transmitters/receivers.

NOTE

The real aircraft also provides for secure voice communications by using a TSEC/KY-58 secure voice encoder. It is not possible to simulate such device in DCS and thus the DCS AV-8B NA does not have this system enabled.

The ARC-210 radio provides transmission and reception of amplitude and frequency modulated (AM and FM) signals on frequencies spaced 25 kHz apart. The frequency range is 30 to 399.975 MHz.

Band	Frequency Range (MHz)	Modulation	GUARD Channel (MHz)
CAS	30.000 to 87.975	FM	243.00
NAV	108.000 to 155.975	AM	121.50
ATC	118.000 to 136.975	FM	243.00
LAND	137.000 to 155.975	FM	243.00
SEA	156.000 to 173.975	FM	243.00
UHF	225.000 to 399.975	AM or FM	243.00

- **CAS Band:** Used to contact ground units during close air support missions.
- **NAV Band (reception only):** These frequencies are used by navigation beacons like TACAN, VORTACS, etc.
- **ATC Band:** This frequency range is used by airports and air traffic controllers.
- **LAND Band:** Used to communicate with portable land based radios.
- **SEA Band:** Marine VHF.
- **UHF Band:** Tactical band.

Both radios (COM1 and COM2) utilize 26 preset channels, a manual (M) channel and an emergency (E) channel. The preset channels and manual channel frequencies are pilot entered. The emergency channel automatically selects a frequency of 243.000 MHz (GUARD).

NOTE

The preset channels can be modified via MISSION EDITOR before the flight start. On initial Early Access release only EASY COMS option is enabled for radio use. Capability to manually change radio frequencies will be enabled on subsequent updates.

Operating Modes

There are two radio control operating modes: Upfront Control (UFC) and Manual (MAN). They are selected by the MODE switch on the ACNIP.

UFC Mode

In the UFC mode, the radios are controlled by the UFC and ODU. This is the main and default mode for controlling the radios.

MAN Mode

In the MAN mode, the radios are controlled by the V/UHF Radio Set Control (RCS) and ACNIP. The manual mode is primarily used as an emergency mode for in-flight failures of the UFC and for ground alert operation when the aircraft does not have AC power.

NOTE

On initial Early Access release only the UFC mode is available. MAN mode will be enabled on subsequent upgrades.

V/UHF Controls and Indicators

The COM1 and COM2 radios controls and indicators are in the UFC, ODU, RSC, ACNIP and the HOTAS COM switch.

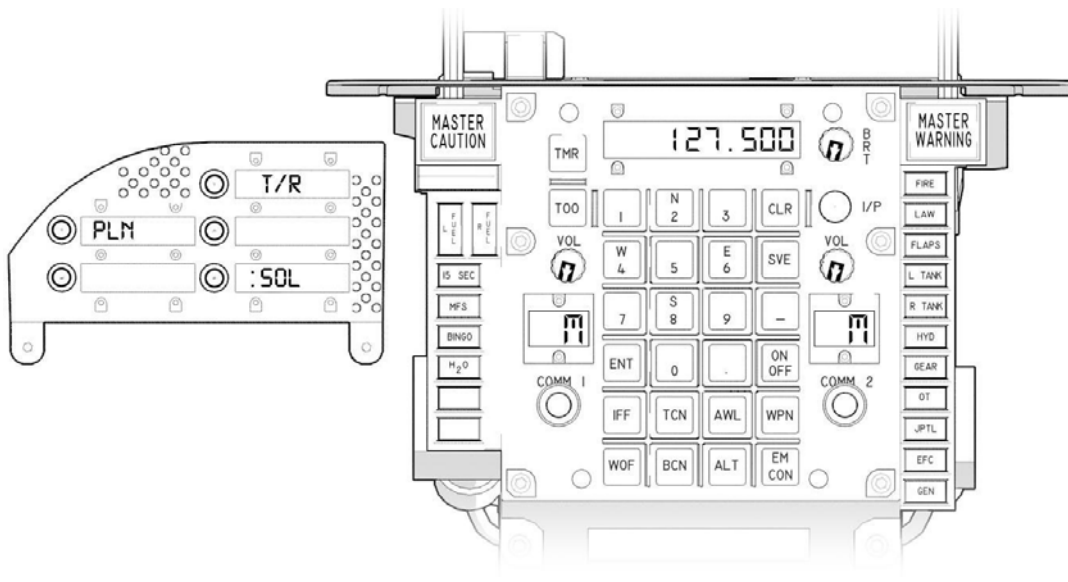

UFC and ODU in COMMUNICATIONS mode

UFC

The pushbuttons and indicators that are used for radio operation and display are the Power/Volume Control, Channel display and Channel Selector. There is one set of them for each radio.

- **Power/Volume Control:** The VOL control on the UFC turns the selected radio on/off and adjust the volume for all operating mode: UFC and MAN. Each radio is independently turned on by rotating the VOL knob clockwise. This rotation also increases the volume.
- **Channel Display:** Indicates the currently selected preset (1 to 26), Manual (M) or Emergency (E) channel. When the display is dark it indicates that the corresponding radio is off. A colon to the left of the display indicates which radio is the active transmitter. A colon to the right indicates which radio is receiving the current transmission.
- **Channel Selector:** Rotating the channel selector knob selects one of the 26 preset channels, manual (M) or emergency (E) channels for the corresponding radio. The channel selector knob is rotatable continuously CW or CCW to the desired station. The stations are consecutive 1 – 26 – M – E and repeat the sequence at the beginning or end of the same.

Either pressing the channel selector knob or rotating it enables the UFC to display the radio options available to the selected transmitter/receiver. Each radio option is independent.

ODU

- **Option 1:** Clicking on the Option 1 button (OB1) toggles between T/R (transmit/receive), TR+G (transmit-receive + guard) or G (guard). If guard is selected, the radio channel is overridden.
- **Option 2:** This option is only available when the selected frequency is between 225.000 to 400.000 MHz. It toggles between AM or FM modulation. Otherwise it is blank.
- **Option3:** Clicking on this option toggles squelch on/off. A colon (:) is shown on the left side when squelch is active.
- **Option 4:** This option toggles between cipher modes: PLN (plain), CIPH (cipher) and DLY (delay). PLN is the default mode and it is the only working mode since DCS does not have communications encryption. The other two modes are for realism completion
- **Option 5:** It selects which cipher code index to use when not in PLN mode. If PLN is selected this option remains blank. The cipher code index 1 thru 6 is changed via UFC keyboard. This option does not have any effect on communications since DCS does not have communications encryption.

V/UHF Radio Set Control (RCS)

This control is not available on initial Early Access release. Its description and functionality will be detailed on subsequent updates.

Emission Control

Emission Control is a special mode in which all the aircraft active transmitters: Radios, TACAN (if in T/R or A/A modes), RADAR Beacon and Radar Altimeter are placed in standby in order to enforce radio emissions silence.

EMCON Controls and Indicators

The EMCON control and indicator is the UFC.

UFC

The pushbuttons and indicators that are used for EMCON operation and display are the EMCON and ON/OFF buttons and the scratchpad.

- **EMCON button:** Sets the UFC for EMCON control mode. The scratchpad will display EMCON on the left side and the word ON will appear if the aircraft is in EMCON mode.
- **ON/OFF button:** Activates/Deactivate the aircraft's EMCON mode. Clicking on this button will toggle between on and off.

NOTE

The Radar Altimeter (RADALT) will be placed on standby when the aircraft is in EMCON, but under certain tactical considerations it will automatically be turned on in order to update current AGL altitude and immediately put back in standby, without pilot intervention.

NOTE

EMCON mode is not available on initial Early Access release. It will be made operational in subsequent updates.

SENSOR MANAGEMENT

The AV-8B Night Attack has three built-in sensors: The INS, Angle Rate Bombing System (ARBS) and the FLIR. Of these three, the INS and the ARBS are used for target selection and ordnance delivery computations.

Sensor Select Switch (SSS)

The sensor select switch is a six-position switch (center off). It uses five momentary positions: forward, aft, left, right and down. The forward and aft selections are mutually exclusive but do not affect the selections made with the left or right actuations.

- **SSS Forward** selects the INS sensor mode and in A/G, NAV or VSTOL master mode assigns the TDC to the HUD. To provide a cue that the TDC is assigned to the HUD a dot is displayed in the middle of the velocity vector.

If an IR or CCD Maverick missile is the selected weapon, this will activate the missile's seeker as the aircraft's targeting sensor. Subsequent actuations will toggle between INS and MAV sensor modes.

- **SSS Aft** selects the ARBS sensor mode and in A/G, NAV or VSTOL master mode assigns the TDC to the DMT. The first actuation sets the ARBS in Laser Spot Tracking mode (LST), the next actuation sets the ARBS in TV mode. Subsequent actuations will toggle between LST and TV modes.
- **SSS Left** If not EHSD page is displayed in either MPCD, the first actuation will select the EHSD main page in the Left MPCD. Subsequent actuations toggle between the EHSD center and decenter modes.
- **SSS Right** If no FLIR display is selected in either MPCD the initial actuation selects the FLIR display in the right MPCD. Subsequent actuations toggle between FLIR white hot/black hot polarity.
- **SSS Down** Also known as the HUD scene reject. If the HUD brightness selector switch is in the NIGHT position displays/reject FLIR video on the HUD. If the TPOD is loaded it assigns the TDC to the TPOD. Please refer to the LITENING II chapter for more information on the TPOD TDC assignment.

Please refer to the control stick illustration to locate the Sensor Select Switch and its keybinds.

Target Designator Control (TDC)

The TDC is a switch with lateral displacements in all directions. It is located in the throttle for thumb operation and incorporates both action and no action slewing in combination with fast and slow slew rates. It is used for sensor designation slewing and commanding MAP, FLIR, INS or ARBS/TV sensor designation.

TDC designates a target by clicking on the [TDC Down (Action Position)] key. Target designation occurs upon key release.

Please refer to the throttle illustration to locate the TDC and its keybinds.

NOTE

TDC Action/No Action modes along with TDC axis command are not available in the initial Early Release version. They will be made operational in subsequent releases.

Internal Sensors

INS

The INS is a self-contained, fully automatic dead reckoning navigation system that detects aircraft motion and provides acceleration, velocity, present position, pitch, roll and true heading to related systems. When the INS is coupled with the GPS (IFA mode) the need for present position updates is eliminated.

INS Target Designation

The INS can be used for target designation. The INS mode uses either coordinate position (waypoint, waypoint offset, mark, mark offset positions) or HUD symbol LOS angles, inertial velocities and either barometric or radar altitude to determine the release solution.

Angle Rate Bombing System (ARBS)

The ARBS is a passive system that provides day and night attack capability by using either reflected light images (TV mode) or reflected laser energy (LST mode).

The angle rate concept allows for a simple system that substitutes mathematical sophistication for hardware complexity.

The ARBS utilizes rate of change of the Line of Sight (LOS) between the aircraft and target to compute slant range. Once this value has been computed, the system will provide the solution for an automatic weapons release to impact the designated target.

The ARBS consists of the following components:

- Dual Mode Tracker (DMT).
- Air Data Computer (ADC).
- INS
- Stores management system (SMS)

These components supply inputs to the mission computer which processes the information to calculate weapon's delivery parameters

Dual Mode Tracker (DMT)

The DMT is the heart of the ARBS. It is located in the nose of the aircraft and is capable of tracking both TV (contrast) and laser designated targets. It affords the pilot with a 6x magnified image of the target.

The DMT receiver/processor contains a TV vidicon and laser detection circuitry. Both devices share the same optics system. It also incorporates sun shutters, to protect the TV vidicon from being damaged by direct sunlight, and two filters used for high and low ambient light conditions.

The DMT TV vidicon is a daylight only device. It has no night vision capability whatsoever.

The DMT LST also provides target video once the system is tracking a laser spot.

DMT Controls and Indicators

The DMT controls and indicators are: DMT power switch, Sensor Select switch and either MPCD.

- **DMT power switch:** The DMT power switch is a two-position switch located on the miscellaneous control panel. The up position (DMT) applies power to the DMT unit. The down position (OFF) removes power. When the switch is in the off position, the DMT gimbals are not caged and instead relies on balance and soft stops for sensor protection. It is desirable to keep the DMT on during aircraft operation for better sensor protection although it is not a requirement.
- **Sensor Select Switch:** Please refer to the SSS notes in this chapter.

- **MPCD:** DMT video is displayed on either left or right MPCD. If DMT video was not available in any MPCD, when the SSS requests DMT vide, the right MPCD will immediately change to DMT mode.

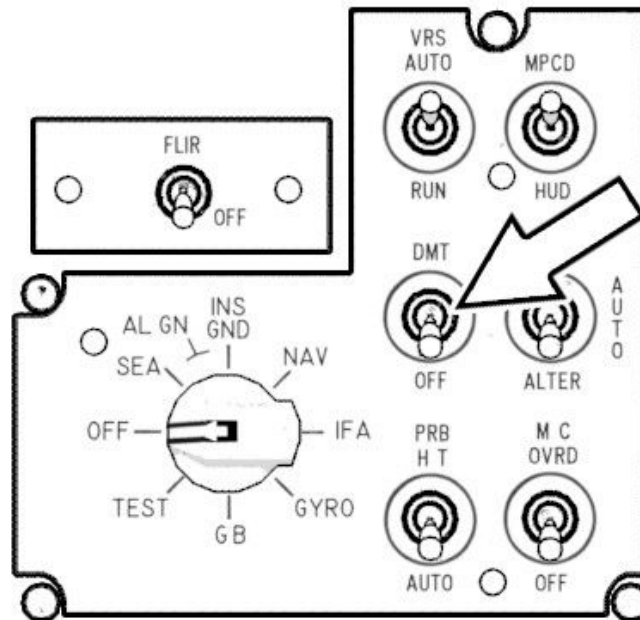

DMT switch in the Miscellaneous Control Panel

DMT Display

The DMT display can be called in two ways: By clicking on the DMT button (PB3) in the MPCD main menu or by selecting the ARBS Sensor mode by clicking the [Sensor Select AFT: DMT: LST/TV] Key.

The DMT display has two modes:

- DMT without Video, and
- DMT with Video

DMT without video:

DMT without video is a special display in which the ARBS temporarily sets the INS as the main sensor when for any reason the DMT TV camera cannot track a designated target, such as:

- When the ARBS is in LST mode and is trying to detect the laser spot.
- When the DMT TV/LST has reached its gimbal limits when tracking a designated target.
- When the DMT sun shutters have been activated to protect the lenses.

When DMT without video display is active, the DMT displays a page very similar to the EHSD main page.

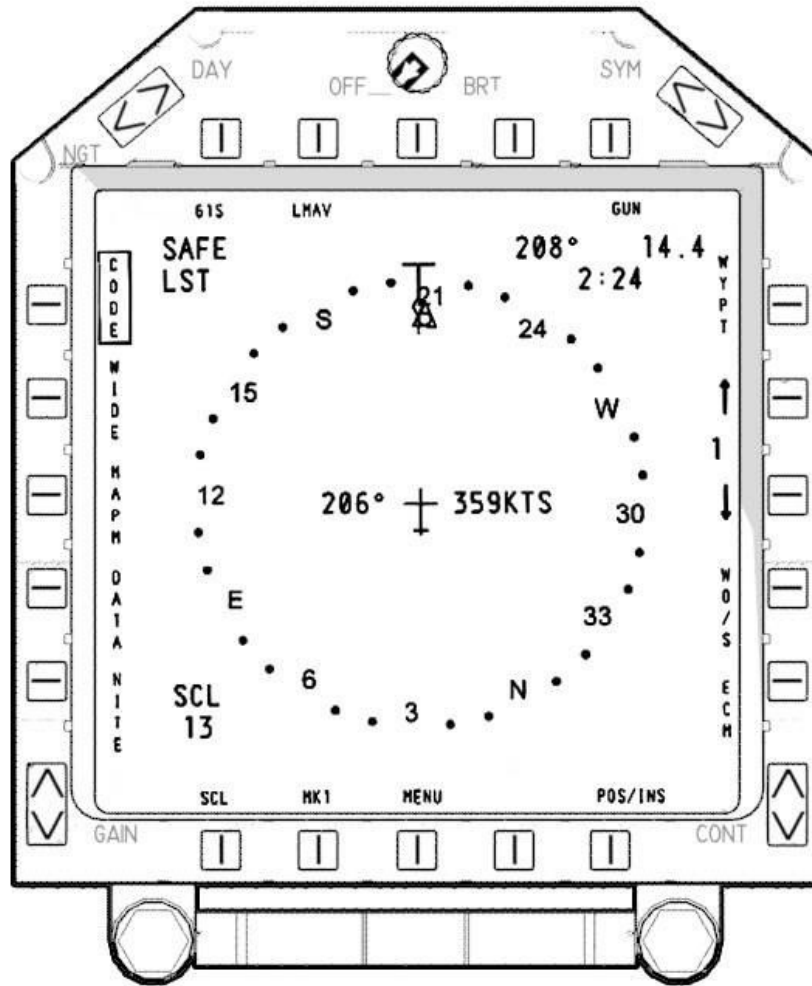

DMT without Video display

The options and data displayed depends on the ARBS status at the time the DMT without video is displayed:

ARBS/DMT Options:

CODE: When selected (boxed) enables the UFC for laser code input.

LST Scan pattern: Wide (WIDE), narrow (NAR) and HUD (HUD). This is the scan pattern used by the LST to seek for a laser spot. (Default is WIDE).

NITE: The NITE option when selected (boxed) disables the DMT TV vide and shows only the DMT without video display. It is used to prevent the ARBS vide from temporarily blinding the pilot during night conditions.

Data:

The data displayed depends on whether a target has been designated or not. With a designated target, the information provided is: Bearing to target, distance to target (NM) and Time-To-Go (minutes:seconds). A small square will be shown in the page indicating the target position in relation to the aircraft. If no target has been designated the information provide is related to the current waypoint. Waypoint selection is enabled so the pilot can change current waypoint at will.

DMT with video:

DMT with video shows a video image from the DMT TV camera with 6X magnification. The magnification is fixed and cannot be changed by the pilot. It can be used to visually designate/track a target.

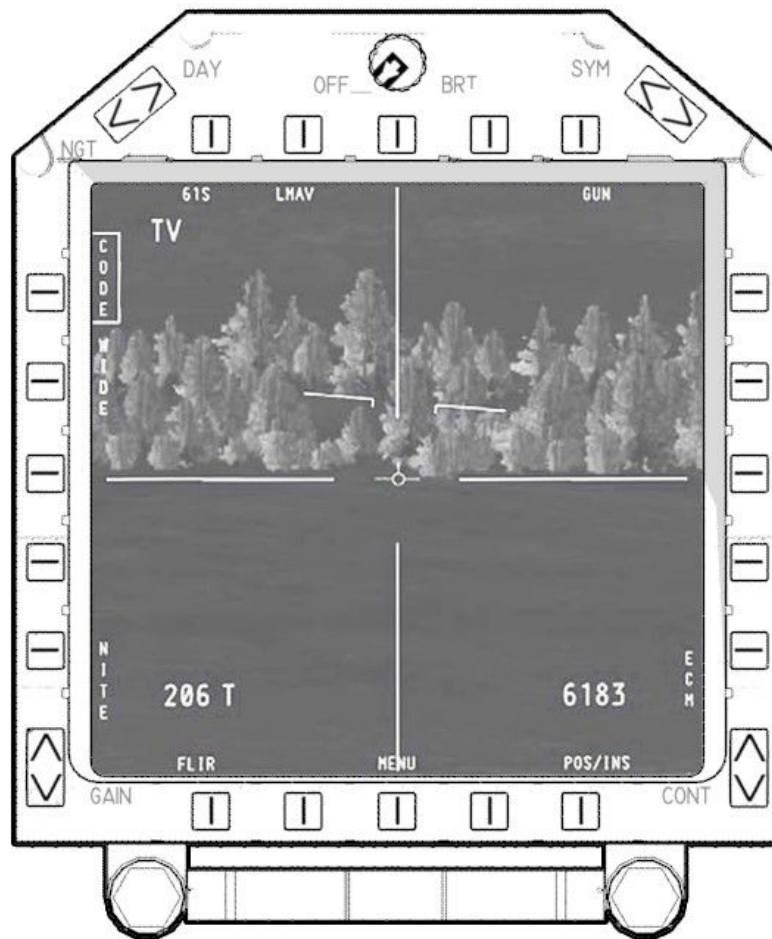

DMT with Video display

When no target has been designated the cross hairs will be open and a fixed aircraft symbol will be shown on the center of the video. Also, a horizon bar will be displayed to show aircraft attitude.

When a target is designated the crosshairs are closed and the target is boxed. Both the aircraft and attitude symbols are removed from the screen.

ARBS/DMT Options:

CODE: When selected (boxed) enables the UFC for laser code input.

LST Scan pattern: Wide (WIDE), narrow (NAR) and HUD (HUD). This is the scan pattern used by the LST to seek for a laser spot. (Default is WIDE).

NITE: The NITE option when selected (boxed) disables the DMT TV vide and shows only the DMT without video display. It is used to prevent the ARBS vide from temporarily blinding the pilot during night conditions.

FLTR: The FLTR option selects which TV filter is used: yellow or red. Yellow filter for low light conditions while Red filter is for normal light conditions. When Yellow filter is selected the FLTR legend will be boxed.

Selected Sensor Status

In both DMT without video and DMT with video displays the selected sensor status is shown in the upper left corner of the active display. The selected sensor status are:

- **INS:** When the selected sensor is the INS.
- **LST:** When the selected sensor is the ARBS in LST mode.
- **TV:** When the selected sensor is the ARBS in TV mode.
- **MAV:** When the selected sensor is IR or CCD Maverick missiles.

NOTE

All AV-8B NA video displays use green, not grey. Due to a DCS limitation we have been forced to use greyscale. The video output will be changed to green as soon as the texture is available in DCS.

ARBS Target Designation

When there is no designated target the ARBS/DMT sensors will be slaved to the Velocity Vector. The recommended procedure to select and designate a target is to place the VVM on the selected target and click on the [TDC Down (Action Position)] key.

LST Mode

Initially place the aircraft VVM in the general area where the laser spot is, the LST will soon move towards the spot and lock it.

Once the spot has been locked the DMT with Video page will be displayed allowing the pilot to visually track the target.

TV Mode

Either using the VVM in the HUD or the TV display, place the VV over the selected target and click [TDC Down (Action Position)] key. Afterwards you can use the TDC to “sweeten” the target designation.

NOTE

Currently the ARBS/DMT TV Mode cannot lock to moving targets. This is still under review. This option may or may not be available in the future depending on available documentation.

NOTE

The ARBS/DMT sensor mode will be subject to modifications/upgrades after the initial Early Release. Such changes will be informed in due time.

NOTE

INS designated targets can be transferred to the ARBS and vice versa. All you have to do is change the selected sensor after the target has been designated.

FLIR

The AV-8B Night Attack has a built in FLIR system that is mainly used for navigation called NAVFLIR. The NAVFLIR system consists of two main units: The sensor head and the electronics unit.

The NAVFLIR sensor head is mounted directly to a boresight adaptor tray in the upper portion of the nose cone in front of the windscreen and is responsible for the distinctive fairing on the aircraft's nose. The electronics unit is located directly beneath the sensor head.

The NAVFLIR sensor head field-of-view (FOV) is fixed at the aircraft waterline and is 2° above the horizon in level flight. Its coverage is 13.4° in elevation and 20° in azimuth. The sensor head detects IR signals which is then converted to electrical signals in order to provide an analog representation of the IR scene.

In order to detect the IR energy the sensor head must be cooled. Instead of using a liquid nitrogen like the Sidewinder seeker head, the system uses a cooling engine that is powered by the aircraft. This system provides slower cool down times (between three and five minutes depending on ambient temperature) than the Sidewinder system.

NOTE

NAVFLIR cool down time is not enabled in initial Early Access release. The system will be enabled in subsequent updates.

NAVFLIR Polarity

NAVFLIR polarity can be switched from White Hot to Black Hot and vice versa.

NAVFLIR Controls and Indicators

The NAVFLIR controls and indicators are: FLIR power switch, Sensor Select switch, HUD control panel and either MPCD.

- **FLIR power switch:** The FLIR power switch is a two-position switch located on the NAVFLIR power panel. The up position (FLIR) applies power to the NAVFLIR sensor and electronics unit. The down position (OFF) removes power. When the switch is clicked to the FLIR position the NAVFLIR cool down process is initiated. The NAVFLIR is operational in less than 5 minutes. Until then, with the FLIR display selected on either MPCD a NOT RDY legend will be shown.
- **Sensor Select Switch:** Clicking on [Sensor Select RIGHT: FLIR: Video On/WH/BH] will select FLIR video on the right MPCD, if FLIR video was not available before. Subsequent actuations will alternate between white hot and black hot polarity.

Clicking on [Sensor Select DOWN: HUD Scene Reject/TPOD] will display FLIR video on the HUD, if the HUD brightness selector is in the NIGHT position. Subsequent actuations of [Sensor Select DOWN: HUD Scene Reject/TPOD] will toggle the FLIR video on the HUD between off and on.

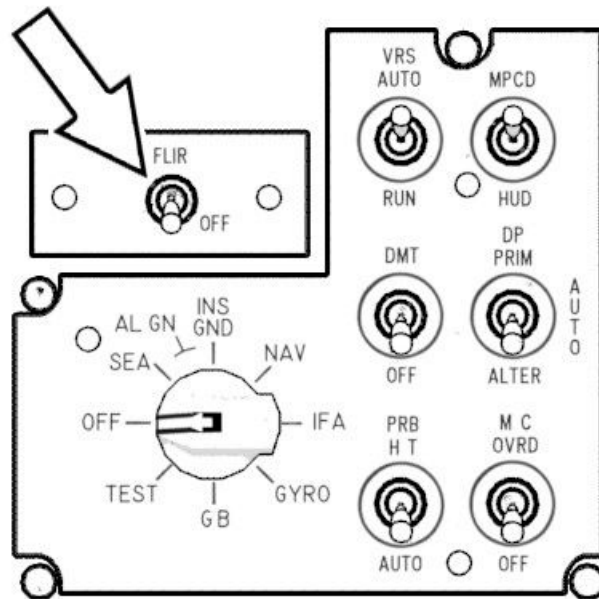

FLIR power switch

- **HUD Control Panel:** HUD FLIR video display and controls are provided by controls and switches on the HUD control panel.
 - **Brightness selector (DAY/NIGHT/AUTO):** This switch is in the middle of the panel. It must be moved to the NIGHT position to enable FLIR video to be displayed on the HUD.
 - **Video Brightness Control (BRT):** Adjusts the brightness of the HUD FLIR video. Clicking on the BRT control swaps the display on the two MPCDs.
 - **Video Contrast (CONT):** Adjusts the contrast of the HUD FLIR video.



HUD Control Panel FLIR video controls

NOTE

The Brightness function of the Brightness Selector switch, Video Brightness Control and Video Contrast functions are not enabled in the initial Early Access Release. They will be enabled in subsequent updates.

NAVFLIR Hotspot Detector

The NAVFLIR can be used as a target detector device thanks to its hotspot detector. The hotspot detector as its name implies detects all high temperature differentials in the terrain in front of the NAVFLIR sensor. These differentials are then displayed in the FLIR video with a “V” symbol. The pilot can determine how many target cues he wants displayed by selecting the LIM option in the FLIR video display on the MPCD. There are three selections: LIM/0 (no cues are displayed), LIM/4 (four cues max.) and LIM/8 (eight cues max.).

The hotspot detector helps the pilot concentrate on possible target locations and select one for attention. Once he has selected a target, it must be designated so targeting information for weapons release is available.

Hotspot cues are not available in the VSTOL master mode.

NOTE

The real NAVFLIR hotspot detector has more features and options that cannot be simulated on DCS. One of these features is sensibility. The real NAVFLIR hotspot detector will detect ALL temperature differentials which creates many false readings. Unfortunately, it is not possible to simulate such sensibility in DCS, so the hotspot detector is limited to detection of active vehicles (AI or player controlled vehicles). The hotspot detector in DCS will not mark buildings or scenery objects.

NOTE

NAVFLIR Hotspot Detector is not available on initial Early Access release. The system will be enabled in subsequent updates.

NAVFLIR Target Designation

The NAVFLIR does not have any target designation capability. To designate a target marked by the hotspot detector, the pilot must use either the INS, ARBS or TPOD sensors.

External Sensors

Supplementing the inboard sensors, the AV-8B Night Attack can also carry and interface with external sensors carried in the aircraft's pylons as either sensor pods or some weapons seeker heads.

Litening II Pod (TPOD)

The AN/AAQ-28 Litening II targeting Pod (TPOD) is a multi-sensor targeting system developed to provide the AV-8B with precision strike capability against surface targets.

For more information on the TPOD please refer to the LITENING II TARGETING POD (TPOD) chapter.

Maverick (IR & CCD)

The AGM-65D (IR), AGM-65G (IR), AGM-65H (CCD) and AGM-65K (CCD) seeker heads have video capability and as such they can be used as supplemental sensors in the aircraft.

For more information on using Mavericks please refer to the AGM-65 MAVERICK section in the WEAPONS MANAGEMENT chapter.

WEAPONS SYSTEMS

The AV-8B Night Attack is designed to provide close air support by combining the speed and firepower of a jet attack aircraft with a unique basing flexibility. The aircraft incorporates an integrated weapons system which uses inputs from various sensors to provide enhanced target acquisition and accurate weapon delivery.

The AV-8B Night Attack provides this capability during the day and at night thanks to passive sensors like a digital moving map, a navigational forward looking infrared system (NAVFLIR) and night vision goggles (NVG).

Weapons Management

The AV-8B stores management system consists of the following elements:

- **Stores Management Computer (SMC):** A digital computer that stores the aircraft weapons loadout, supplies the stored weapons ballistic coefficients for delivery calculations and also stores weapon delivery programs.
- **Stores Station Controllers (SSC):** One on each pylon for a total of seven. The SCC controls jettison and release functions with a mechanical backup in case of system failure.
- **Armament Control Panel (ACP):** The ACP, located on the lower left main instrument panel, contains the controls and indicators for the SMC. The panel has display windows that indicate the weapons program that can be set by the pilot via the adjacent switches or the UFC and ODU. Please refer to the Weapons Programming section for a more detailed description of the ACP.
- **Hands on Throttle and Stick (HOTAS):** Please refer to the HOTAS section for a more detailed description of HOTAS weapons functions.

Hands on Throttle and Stick (HOTAS)

Throttle controls

1. *Target Designator Control (TDC)*

The TDC is a switch that moves in all direction and provides output for the display cursor (TD diamond) and/or sensor control. The TDC incorporates both action and no-action slewing:

- **Action slewing (TDC pressed):** is used primarily for target acquisition and designation.
- **No-action slewing (TDC not pressed):** is used primarily for sensor control and “sweetening” of target track after a target has been designated.
- **Target designation (TDC press with or without slewing):** is used to select the target under the display cursor and/or sensor cursor as the aircraft’s designated target. **Target designation happens after the TDC is released.**

2. *Cage/Uncage Button*

The cage/uncage button is a momentary pushbutton switch. Its functionality depends on aircraft master mode and selected weapon.

- **A/A Master Mode:**
 - **GAU-12 Gun pod:** Toggles between the long and the short range gunsight.
 - **Sidewinders:** Clears any missile lock.
- **A/G Master Mode:**
 - **Bombs:** Alternates between CCIP and AUTO (CCRP) delivery modes.
 - **Rockets:** Toggles between CCIP and fixed sight.
 - **GAU-12 Gun pod:** Toggles between CCIP and fixed gunsight.

- **Mavericks:** Uncages the missile seeker head to start scan. If the missile is an IR or CCD variant it displays seeker head video in the left MPCD. Refer to the AGM-65 Maverick section for more information.

Control Stick controls

1. Trigger switch

The trigger switch fires the GAU-12 gun or Sidewinder missiles when in A/A master mode. In A/G master mode it is used to fire the GAU-12 gun and to launch AGM-122 Sidarm missiles.

2. Bomb Pickle Button.

This switch is only active in the A/G master mode. It is used for release of bombs, rockets, flares and to launch Maverick missiles.

3. A/A Weapon Select Switch.

This is a three-position momentary switch that automatically selects the A/A master mode when an A/A weapon selection is made.

- **Aft:** Selects Sidewinder in expanded acquisition mode (SEAM). Please refer to the AIM-9M Sidewinder section for more information on SEAM.
- **Forward:** Selects Sidewinder in boresight mode (SW).
- **Down:** Selects the GAU-12 Gun pod.

Stores display

The stores display is called by clicking on the STRS (PB4) on the MPCD main menu. It displays the type, number and status of all weapons loaded in the aircraft. It also presents the selected weapon delivery program data.

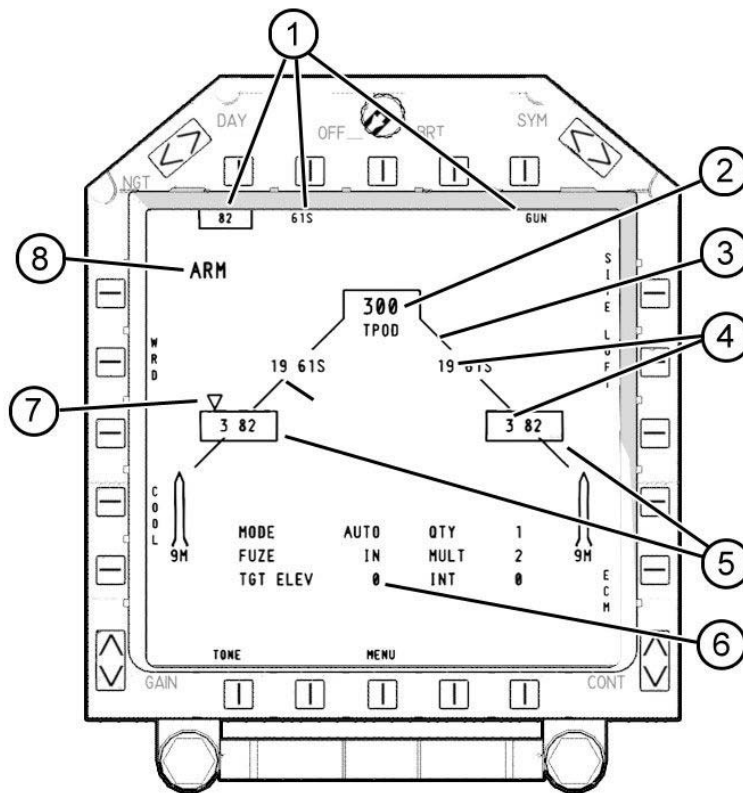

MPCD Stores page

1. Weapons available for selection. (Selected weapon is boxed)
2. Centerline load: Gun ammo (if gun pod is present) and centerline pod (if loaded).
3. Wing form display.
4. Loaded weapons and quantity available (per station).
5. Selected weapons (boxed).
6. Selected weapon delivery program.
7. Priority Station marker.
8. Master Arm Status (ARM/SAFE).

Armament Control Panel (ACP)

The ACP contains controls and indicators for interacting with the stores management computer (SMC).

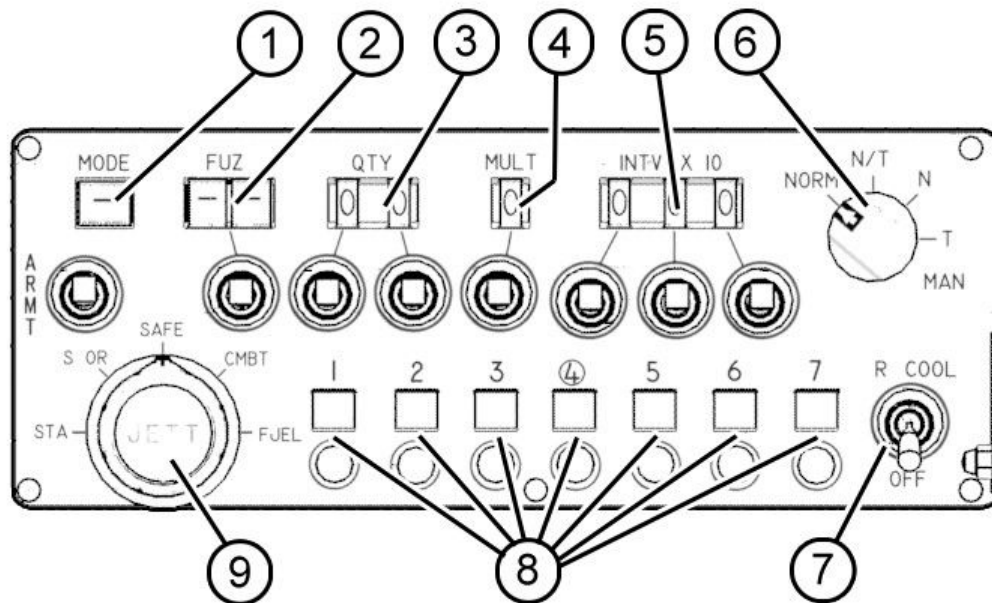

1. **Delivery Mode Control:** The delivery mode control is a three-position switch with two momentary UP and DOWN positions and a center OFF position. The control selects the weapon delivery mode:
 - a. AUT (Automatic)
 - b. CIP (CCIP)
 - c. DSL (depressed sight line)
 - d. DIR (direct)

The window above the switch displays the selected delivery mode. The delivery mode is selected by clicking the switch either UP or DOWN.

Only mode selections applicable to the selected weapon are available.

Whenever an air-to-ground missile, like the Maverick or the Sidarm, has been selected, the ACP will automatically select AGM mode. This mode cannot be selected by the pilot.

DIR mode is automatically selected in case of SMC failure.

2. **Fuzing Control:** The fuzing control is a three-position switch similar to the Mode Control. This control selects the weapon fuzing option. Like the Mode control only the fuzing options applicable to the selected weapon are available. For some weapons, there are no pilot-configured fuzing options. In these cases, a dash (-) will be shown in the option windows

3. **Quantity Control:** The quantity control consists of two three-position switches. The switches select the quantity of weapons to be released during a delivery sequence. The two windows display the selected quantity.

A quantity greater than the number of selected weapons aboard cannot be selected.

4. **Multiple Control:** The multiple control is a three-position switch. It selects the number of stations that will simultaneously release their weapons during a delivery sequence. The window displays the selected multiple.

The multiple control cannot be set to a number greater than the number of stations carrying the selected weapon.

Please refer to the MULTIPLE RELEASE section for more information.

5. **Interval Control:** The interval control consists of three three-position switches. This control sets the release interval for a multiple release sequence. The interval selected represents the ground impact spacing in feet.

Please refer to the MULTIPLE RELEASE section for more information.

6. **Manual Control:** The manual control knob places the SMC in the DSL (manual) delivery mode and selects backup (mechanical) arming. The options are:

- **NORM:** Normal (default mode).
- **N/T:** Nose and tail fuzing.
- **N:** Nose fuzing.
- **T:** Tail fuzing.

Placing the knob in N/T, N or T position will cause the SMC to enter into manual mode and will override computed release modes. Weapons programming is disregarded.

Please refer to the MANUAL RELEASE section for more information.

7. **IR Cool Switch:** The IR cool switch is a two-position switch. It enables the pilot to manually apply IR detector cooling to the sidewinder seekers for pre-flight operation or as a backup mode in case of SMC failure.

Clicking the switch to the IR COOL applies cooling to all sidewinder station that has a sidewinder or sidearm loaded. Clicking the switch to the OFF position deselects IR cooling.

The IR COOL switch must be in the OFF position prior to flight.

Please refer to the AGM-122 SIDEARM section for more information.

8. **Station Select Buttons:** The station select buttons are located at the bottom of the ACP. There are seven buttons, one for each armament station. An indicator window above the button will indicate station selection (SEL) an deselection (–). The buttons enable the pilot to select weapons for release in all modes.

With the MANUAL CONTROL knob in NORM and when the selected delivery mode is AUT, CIP or DSL, selecting a station will select the weapon type, meaning all stations carrying the same weapon will be selected. Station priority for weapon release will be determined by the SMC.

Selecting a station carrying another weapon type will deselect all the previous selected stations and select all the stations carrying the new selected type.

Selecting a station that carries the currently selected weapon type will deselect all stations carrying the same type.

With MANUAL CONTROL knob in N/T, N or T or if the selected delivery mode is DIR, selecting a station will only select/deselect that specific station, the other station status will not change. The SMC will not set priority release. The pilot is responsible for ensuring that all selected stations carry the same weapon type.

- 9. Selective Jettison Control:** The selective jettison control consists of a rotary knob and a pushbutton. The knob selects the jettison mode and the pushbutton initiates the jettison procedure.

When the rotary knob is not in the SAFE position, weapons release is inhibited. Please refer to the SELECTIVE JETTISON section for more information.

NOTE

MANUAL delivery mode is not enabled in initial Early Access release. It will be enabled in subsequent releases.

NOTE

All Delayed detonation fuzing options have the D word in the code. In DCS these delays are exaggerated. In real life, the delay is in microseconds to allow for weapon penetration. Other fuzing options do not have any effect on weapons performance since they are not simulated by DCS.

[Weapons Programming](#)

Weapons programming is the procedure by which the pilot configures the SMC with the delivery options for a selected weapon. One delivery program for each weapon type can be entered and stored in the SMC (plus the GAU-12 gun pod). The stored delivery program is recalled when the weapon is selected for delivery.

Only A/G weapons delivery can be programmed (including the gun pod).

The available delivery programming options per weapon type are:

WEAPON	QTY	MULT	INTV	FUZ	MAX/MIN Range cue
<i>Bomb</i>	X	X	X	X	
<i>Rocket</i>	X	X			X
<i>Dispensers</i>	X	X	X	X	
<i>AGM</i>	X			X	
<i>GUN</i>					X

Weapons Programming can be performed either by using the ACP or the UFC and ODU.

[UFC and ODU Weapons Programming](#)

The UFC and ODU are available for weapons programming by clicking on the WPN function button on the UFC. The WPN button is functional only when a weapon is selected and only in the A/G, NAV and VSTOL master modes.

When WPN is clicked, the allowable programming options are displayed on the ODU.

NOTE

UFC and ODU weapons programming is not available in the initial Early Access release. It will be enabled in subsequent releases.

ACP Weapons Programming

Programming options available on the ACP are: Delivery Mode (MODE), Fuzing (FUZ), Quantity (QTY), Multiple (MULT) and Interval (INTV). Only the allowable options for the selected weapon will appear in the associated display window. Options are changed by using the switches below the display windows.

Multiple Release

Multiple weapons release is a function of two factors: The Release Quantity and the Multiple.

Release quantity is the number of weapons to be release on a single delivery sequence. Minimum number is 1 and maximum number is total amount of weapon type onboard the aircraft. The value of quantity indicates the number of release pulses that will be made on each delivery sequence.

Multiple is the number of stations that will simultaneously release a weapon during a single delivery sequence. Minimum number is 1 and maximum number the total count of stations that have the selected weapon type.

The SMC has override capability if the selected quantity + multiple release is not possible.

A delivery sequence is started the moment the pilot clicks on the Bomb Pickle button.

The multiple release works as follows:

Case 1:

Sample weapons load:

STA 1	STA 2	STA 3	STA 4	STA 5	STA 6	STA 7
MK-82	MK-82 x 3	MK-82 x 3		MK-82 x 3	MK-82 x 3	MK-82

QTY = 2 and MULT = 1. Total weapons to be delivered: 2

RELEASE PULSE	STA 1	STA 2	STA 3	STA 4	STA 5	STA 6	STA 7
1st	MK-82						
2nd							MK-82
Final Count		MK-82 x 3	MK-82 x 3		MK-82 x 3	MK-82 x 3	

Case 2:

Sample weapons load:

STA 1	STA 2	STA 3	STA 4	STA 5	STA 6	STA 7
MK-82	MK-82 x 3	MK-82 x 3		MK-82 x 3	MK-82 x 3	MK-82

QTY = 2 and MULT = 2. Total weapons to be delivered: 4

RELEASE PULSE	STA 1	STA 2	STA 3	STA 4	STA 5	STA 6	STA 7
1st	MK-82						MK-82
2nd		MK-82				MK-82	
Final Count		MK-82 x 2	MK-82 x 3		MK-82 x 3	MK-82 x 2	

Case 3:

Sample weapons load:

STA 1	STA 2	STA 3	STA 4	STA 5	STA 6	STA 7
MK-82	MK-82 x 3	MK-82 x 3		MK-82 x 3	MK-82 x 3	MK-82

QTY = 1 and MULT = 4. Total weapons to be delivered: 4

RELEASE PULSE	STA 1	STA 2	STA 3	STA 4	STA 5	STA 6	STA 7
1st	MK-82	MK-82				MK-82	MK-82
Final Count		MK-82 x 2	MK-82 x 3		MK-82 x 3	MK-82 x 2	

Case 4:

Sample weapons load:

STA 1	STA 2	STA 3	STA 4	STA 5	STA 6	STA 7
MK-82	MK-82 x 3	MK-82 x 3		MK-82 x 3	MK-82 x 3	MK-82

QTY = 2 and MULT = 4. Total weapons to be delivered: 8

RELEASE PULSE	STA 1	STA 2	STA 3	STA 4	STA 5	STA 6	STA 7
1st	MK-82	MK-82				MK-82	MK-82
2nd		MK-82	MK-82		MK-82	MK-82	
Final Count		MK-82 x 1	MK-82 x 2		MK-82 x 2	MK-82 x 1	

Weapons Acquisition & Delivery Modes

Air-to-Air

AIM-9M Sidewinder

The AIM-9M Sidewinder has two acquisition modes:

- **Boresight (BST):** The sidewinder acquisition circle is in a fixed position on the HUD and represents the approximate sidewinder seeker field of view. Targets must be placed inside the circle to obtain target detection and seeker lock on.
- **Sidewinder Expanded Acquisition Mode (SEAM):** In this mode, the sidewinder seeker head rotates around its center in order to expand its field of view. The sidewinder acquisition circle will rotate on the HUD to represent this expanded field of view. Targets must be placed within the circular scan area to obtain target detection and seeker lock on.

NOTE

Sidewinder SEAM mode is not available in initial Early Access release. It will be enabled on subsequent updates.

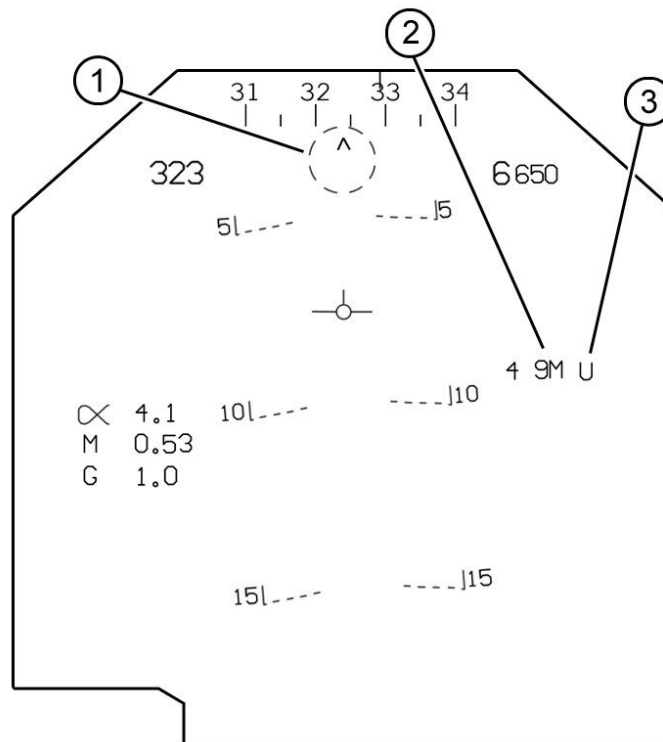

Sidewinder HUD Symbology

1. Sidewinder Acquisition Circle
2. Weapons code and count.
3. Seeker Uncaged Symbol (not shown when Sidewinder seeker is caged).

GAU-12 Gun pod

The GAU-12 Equalizer gun pod can be used in air-to-air combat. There are two reticles provided: a long range and a short range. Either reticle may be selected by the pilot with the cage/uncage HOTAS button.

Probably because on initial A/A gun selection the long range reticle is enabled. It is a small winged dashed circle that is optimized for a range of 2,400 feet.

The short range reticle is larger than the long range reticle. It is a large winged continuous circle that is optimized for a range of 1,200 feet.

A fixed position gun cross is provided. It is displayed at the gun boresight position which is 2 degrees below the waterline.

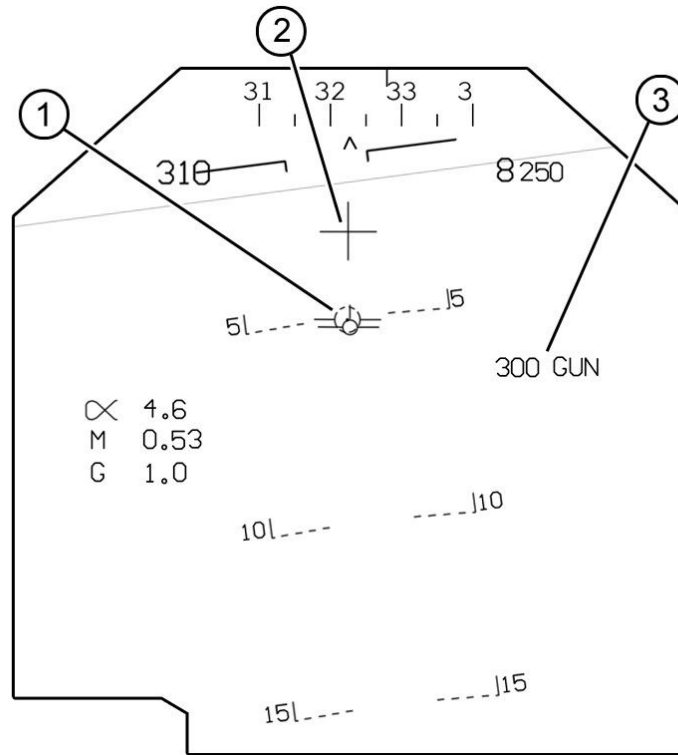

A/A Gun HUD Symbology

1. Long Range Gunsight (Not shown Short Range Gunsight)
2. Gun Boresight Cross
3. Gun Ammunition Count and Selected Weapon Code.

Air-to-Ground

The A/G delivery modes are: automatic (AUTO), loft (LOFT), continuously computed impact point (CCIP), air-to-ground missile (AGM), depressed sight line (DSL), direct (DIR) and DSL(1) a manual mode. Loft is a submode of the automatic delivery mode, DSL, DIR and DSL(1) are backup delivery modes.

STORE	DELIVERY MODE				
	AUTOMATIC		CCIP	DSL	AGM
	AUTO	LOFT			
Bombs	X	X	X	X	
Rockets			X	X	
Gun			X	X	
Dispensers (illumination flares)	X			X	
Air-to-Ground Missiles					X

AUTO Delivery Mode:

This mode works exactly as CCRP (Computer Controlled Release Point). It provides fully computed automatic release of bombs. It requires that the target be designated either via INS, ARBS or TPOD, in order to provide steering commands to the release point.

Steps:

1. Designate Target.
 - a. Azimuth Steering Line (ASL), Time-To-Go (TTG) and release cue (if in range) are displayed if target is in the HUD FOV.
 - b. A steering arrow slaved to the VVM is displayed if the target is outside the HUD FOV. ASL, TTG and release cue are removed from the HUD.
2. Follow the steering commands by executing appropriate delivery maneuvers.
3. When the release cue appears, press the [Bomb Pickle] until bomb release.
4. Bomb(s) will be automatically released.

LOFT Delivery Mode

This mode is not available in initial Early Access release. It will be enabled in subsequent updates.

CCIP Delivery Mode:

The Continuously Computed Impact Point (CCIP) delivery mode is a computed visual delivery mode with manually initiated weapon release. It is selectable by the pilot for bomb deliveries. It is automatically enabled by the ACP when rockets or the gun have been selected.

Bombs:

In CCIP mode, the ground impact point is continuously computed and displayed as a cross on the HUD. The pilot's task is to maneuver the aircraft so the CCIP cross is on the target, at which time the pilot press the [Bomb Pickle] to release bomb

Rockets and Gun

In CCIP mode the aiming reticle is positioned over the computed impact point. The impact point is a function of altitude and computed range to target. The pilot only has to maneuver the aircraft so the

target is inside the aiming reticle and press the [Trigger] for the gun or the [Bomb Pickle] for the rockets.

DSL Delivery Mode

The DSL mode provides a weapons delivery capability should the avionics fail or the pilot feels that a manual delivery is necessary. The DSL mode is only selectable on the ACP. On selection, the roll stabilized reticle is displayed on the HUD.

DIR Delivery Mode

The DIR delivery mode provides a backup weapons delivery capability for limited weapons employment. The system reverts to DIR when the SMC fails.

DIR mode can also be manually selected by deselecting all weapons, selecting A/G master mode and then selecting DIR on the ACP. All weapons programming revert to a default state: FUZ to SAFE, QTY and MULT to 1 and INTV to 0.

This mode uses the roll stabilized reticle on the HUD.

DSL(1) Delivery Mode

The DSL(1) (manual) mode is a backup delivery capability used when both the SMC and the ACP fail. DSL(1) mode is selected by clicking the Manual Control to N,T or N/T. No weapons programming is possible in this mode. This is the only mode in which different weapons type can be selected and released.

This mode uses the roll stabilized reticle on the HUD.

NOTE

DSL(1) (manual) delivery mode is not enabled in initial Early Access release. It will be enabled in subsequent releases.

AGM Delivery Mode

AGM Delivery mode is automatically selected by the ACP when an air-to-ground missile (AGM-65 Maverick or AGM-122 Sidarm). In this mode, the only weapons programming options available is fuzing (for mavericks only).

Individual employment instructions for each missile are detailed in the next section

AGM-65E/TGM-65E Laser Maverick

This missile is not available on initial Early Access release. It will be enabled in subsequent releases.

AGM-65D/G and TGM-65D/G IR Maverick.

The AGM-65D/G IR Maverick (IRMV) is an imaging infrared guided, rocket propelled, air-to-ground missile similar to the AGM-65E Laser Maverick (LMAV). The major difference between IRMV and LMAV is in the seeker, or guidance control section.

The IRMV seeker tracks infrared (IR) significant targets and provides the pilot with a composite video image of the target on the cockpit display. IRMV is capable of being slaved to a target designated by the DMT or to the HUD with an INS designation.

IRMV is a fire and forget missile; however, IR targets must be identified by the pilot and IRMV manually locked onto the target prior to launch.

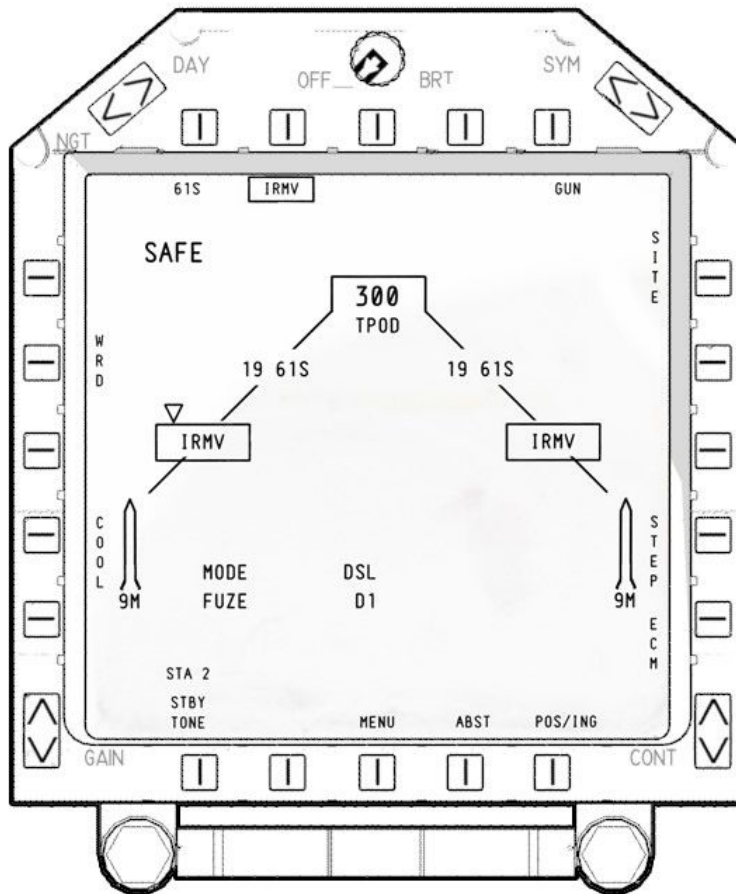

Stores Page with IR Maverick selected

Seeker Cool Down

Like all other infrared seekers, IR Maverick seeker must go through a 3 minute cool down process. The cool down process can only be carried out once the aircraft is airborne (weight-off-wheels).

1. Select the STRS page in the MPCD.
2. Select the IRMV weapon in the top row.
3. All IR Mavericks will be powered and will start the cool down process.
4. The missiles status will be indicated above Button 20: STBY for cool down in process or RDY for missiles ready.
5. Once the cool down process has ended the pilot can either select IR Video or deselect the weapons (the missiles will remain in READY mode for an hour).

ATTENTION

IR Video is not available until the missiles are in READY mode.

IRMV Video Display

IRMV video is only available after the seeker cool down process has finalized (RDY appears on the MPCD). IR Video is always displayed on the LEFT MPCD in place of the STRS display. To select IRMV Video the pilot must press the [Cage/Uncage] HOTAS button. Subsequent activations of the [Cage/Uncage] button will toggle the video on/off.

NOTE

IRMV Video appears on the stores (STRS) page of the LEFT MPCD with each initial [Cage/Uncage] command. If another display is selected while IRMV video is displayed (by pressing the MENU button), select MENU/STRS to return to IRMV Video.

IRMV video cannot be displayed on the RIGHT MPCD.

IRMV Track Polarity (PLTY)

The track polarity function sets the missile seeker to track hot targets on a cold background (hot track) or cold targets on a hot background (cold track). The appropriate track polarity must be selected prior to commanding lock-on. When in hot track, the missile crosshairs are white, while in cold track the crosshairs are black. IRMV initializes on hot track.

Clicking on the PLTY button in the MPCD will toggle between Hot and Cold Track.

IRMV Target Designation and Lock-on

When ready to engage a target, the IRMV should be selected and RDY.

1. Press the [Cage/Uncage] HOTAS Button to activate IRMV Video in the LEFT MPCD.
2. The missile seeker will be slaved to the HUD's VVM. The VVM will show a second circle to indicate that the IRMV seeker is slaved.
3. On the HUD the Missile Type legend will show the letter U, for uncaged.
4. Press the [Sensor Select FWD: INS. IRMV/EOMV] HOTAS Button to select the IRMV seeker as the selected sensor. IRMV label will appear on the IRMV video page.
5. The pilot can designate a target by two methods:
 - a. By placing the HUD's VVM on top of the target. In the IRMV Video page, the target will be in the center of the crosshairs. To command lock press the [TDC Down (Action Position)] HOTAS Button. The seeker will attempt lock as soon as the button is released.
 - b. By slewing the seeker by using the TDC button/axis. The seeker will attempt lock as soon as the button/axis is released.
6. The seeker can be slewed after a target lock is achieved. In which case the lock is cleared and a new lock is attempted.

NOTE

If the IR Maverick seeker fails to achieve lock or the lock is lost, the crosshairs will retract to the edges of the IRMV video display. They will remain there until the seeker is reset by either pressing the [AG Target Undesignate/NWS/FOV Toggle] HOTAS button or by slewing the seeker with the TDC buttons.

AGM-65H/K and TGM-65H/K EO Maverick.

The AGM-65H/K Electro Optical Maverick (EOMV) is an imaging guided, rocket propelled, air-to-ground missile similar to the AGM-65D/G IR Maverick (IRMV). The major difference between EOMV and IRMAV is in the seeker, or guidance control section.

The EOMV seeker tracks shadow contrast in a video image and provides the pilot with a video image of the target on the cockpit display. EOMV is capable of being slaved to a target designated by the DMT or to the HUD with an INS designation.

EOMV is a fire and forget missile; however, video targets must be identified by the pilot and EOMV manually locked onto the target prior to launch.

Seeker Alignment

The EO seeker will start a boresight alignment when the missile is selected and the aircraft is airborne (weight-off-wheels). This process takes a few seconds before the missile is RDY.

EOMV Video Display

EOMV video is only available after the boresight alignment process has finalized (RDY appears on the MPCD). EO Video is always displayed on the LEFT MPCD in place of the STRS display. To select EOMV Video the pilot must press the [Cage/Uncage] HOTAS button. Subsequent activations of the [Cage/Uncage] button will toggle the video on/off.

NOTE

EOMV Video appears on the stores (STRS) page of the LEFT MPCD with each initial [Cage/Uncage] command. If another display is selected while IRMV video is displayed (by pressing the MENU button), select MENU/STRS to return to IRMV Video.

EOMV video cannot be displayed on the RIGHT MPCD.

EOMV Target Designation and Lock-on

When ready to engage a target, the EOMV should be selected and RDY.

1. Press the [Cage/Uncage] HOTAS Button to activate EOMV Video in the LEFT MPCD.
2. The missile seeker will be slaved to the HUD's VVM. The VVM will show a second circle to indicate that the IRMV seeker is slaved.
3. On the HUD the Missile Type legend will show the letter U, for uncaged.
4. Press the [Sensor Select FWD: INS. IRMV/EOMV] HOTAS Button to select the EOMV seeker as the selected sensor. IRMV label will appear on the EOMV video page.
5. The pilot can designate a target by two methods:
 - a. By placing the HUD's VVM on top of the target. In the IRMV Video page, the target will be in the center of the crosshairs. To command lock press the [TDC Down (Action Position)] HOTAS Button. The seeker will attempt lock as soon as the button is released.
 - b. By slewing the seeker by using the TDC button/axis. The seeker will attempt lock as soon as the button/axis is released.
6. The seeker can be slewed after a target lock is achieved. In which case the lock is cleared and a new lock is attempted.

NOTE

If the EO Maverick seeker fails to achieve lock or the lock is lost, the crosshairs will retract to the edges of the IRMV video display. They will remain there until the seeker is reset by either pressing the [AG Target Undesignate/NWS/FOV Toggle] HOTAS button or by slewing the seeker with the TDC buttons.

IR and EO Maverick HUD and MPCD Displays

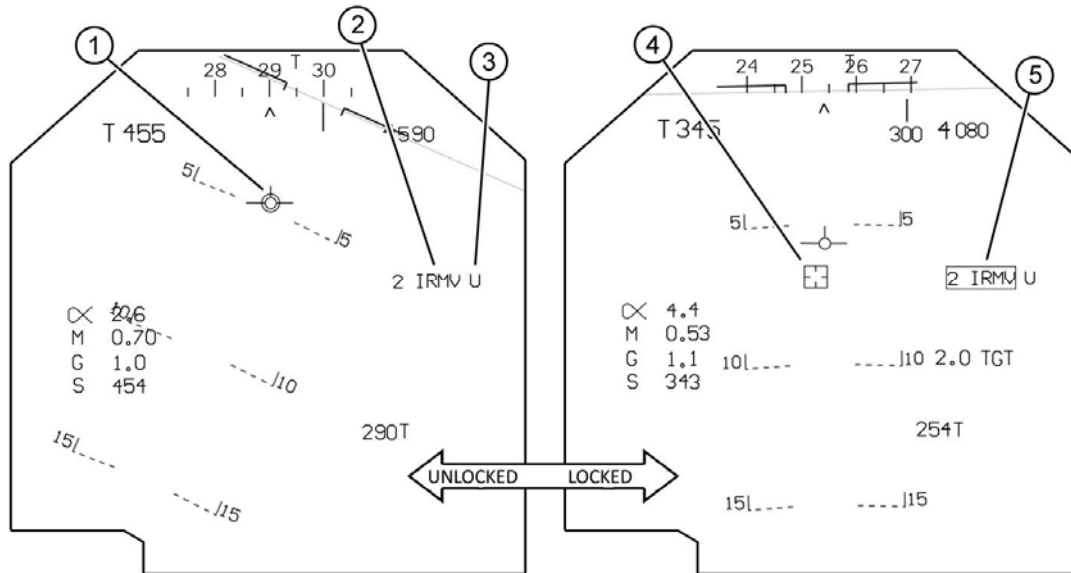

IRMAV and EOMAV HUD Symbology

1. Maverick Seeker slaved to VVM Symbol (No weapons lock)
2. Weapon Code and Count
3. Seeker Uncaged Symbol (not shown when seeker is caged). Indicates that IRMV or EOMV video is displayed.
4. Locked Target
5. IRMV or EOMV Sensor Box. Indicates that the Maverick Seeker is the selected sensor and missile lock is available.

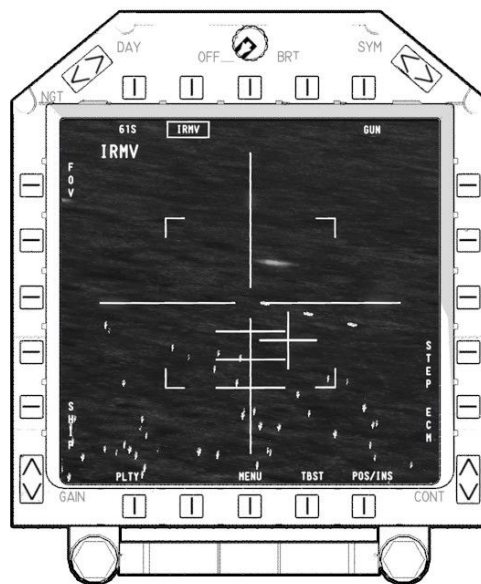

IRMAV Video on LEFT MPCD

AGM-122A Sidarm

The AGM-122A Sidarm is an air-launched, air-to-ground, anti-radiation missile whose mission is to detect, home-on and destroy or disable enemy radars.

The Sidarm is similar to the AIM-9 Sidewinder and with the exception of the guidance and control section, the other weapon components are functionally the same as those used on the Sidewinder.

Sidarm Selection

The Sidarm is selected from either the MPCD or ACP. The Sidarm is displayed on the HUD and MPCD by using the symbol SA.

On the MPCD, the Sidarm uses the same button (PB10) as the GUN legend. To select the Sidarm in the MPCD, the pilot must click repeatedly on the PB10 until the SA legend appears. Further clicks on the button will select the GUN.

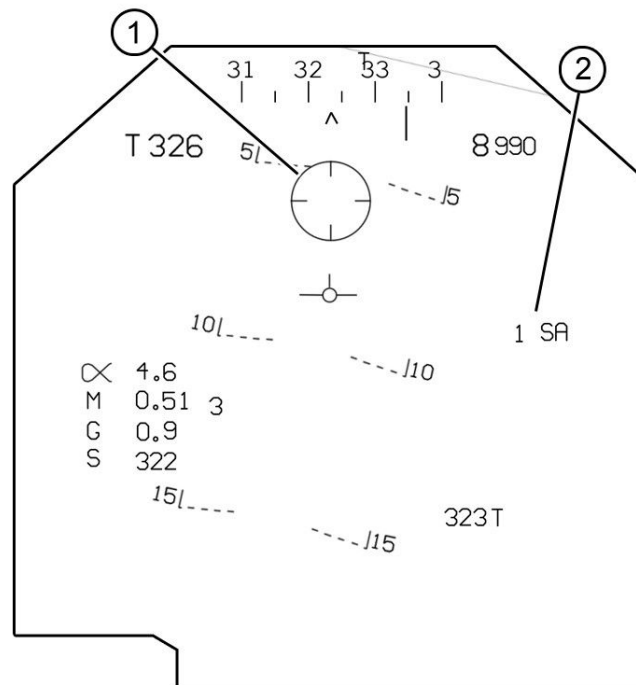

HUD Sidarm Symbology

1. Sidarm Aiming Reticle.
2. Weapon Code and Count.

Sidarm Operation

The Sidarm is a stand alone weapon and is not connected to the RWR. To use the missile, the pilot must maneuver the aircraft until the missile's seeker is pointing towards the threat.

When selected a tone will be heard indicating that the missile is in search mode. The tone will change frequency when a signal is captured. The tone will change again when the seeker has locked on the target. The Sidarm sight will move towards the seeker's target bearing.

The missile will attempt to lock on the strongest radar signal it can detect, which is a function of range, azimuth and elevation. The pilot has no control on which target the missile locks nor has any mean to determine its range. He is the one who must determine if the missile will be fired or not. The pilot can

break lock by pressing the [AG Target Undesignate/NWS/FOV Toggle] HOTAS button, but there is no guarantee that the missile will not attempt lock on the same target again.

NOTE

After a Sidarm launch, the next missile may attempt lock on the same target. To prevent that, deselect Sidarms and reselect again to clear the seeker.

ATTENTION

The AGM-122A Sidarm is a short range weapon. Its maximum range is 16.5 Km (8.9 Nautical Miles). You will be inside the launch envelope of many enemy SAMs systems when using the missile, so plan accordingly.

NOTE

The AGM-122A Sidarm is still under development and at initial Early Release has a low hit probability. The missile reliability will be upgraded in subsequent upgrades.

Weapons Jettison

Jettison is accomplished via the emergency jettison button or the selective jettison button on the ACP.

Emergency Jettison

Jettison all stores on all stations, including their suspension equipment. AIM-9s on Station 1 and Station 7 are retained.

Interlocks

Landing Gear UP **OR** Aircraft is airborne (Weight Off Wheels).

Jettison Control

Emergency Jettison Button (see instruments panel guide).

Jettison Procedure

Click on the Emergency Jettison Button.

Selective Jettison

To activate selective jettison click the Selective Jettison Knob to the appropriate mode. All weapons selection will be cleared and weapons selection on the MPCD and weapons delivery is inhibited.

FUEL

Allows selection of Stations 2, 3, 5 and 6 (wet stations) if they are carrying fuel tanks. Fuel tanks are dropped in pairs: 2 and 6, then 3 and 5.

Interlocks

Landing Gear UP **AND** Aircraft is airborne (Weight Off Wheels).

Jettison Control

Selective Jettison Knob and Selective Jettison Pushbutton.

Jettison Procedure

1. Click the Selective Jettison Knob until it is pointing at the FUEL position.
2. All weapons selection will be cleared and all fuel tank carrying stations will be preselected.
3. Select the stations you want to jettison by clicking on their pushbuttons in the ACP.

4. Click on the Selective Jettison Pushbutton to initiate jettison.
5. Selective Jettison Knob returns to the OFF position when all selected stations have been jettisoned.

COMBAT

Jettison all stores on all stations, including their suspension equipment. AIM-9s on Station 1 and Station 7 are retained.

Interlocks

Landing Gear UP **AND** Aircraft is airborne (Weight Off Wheels).

Jettison Control

Selective Jettison Knob and Selective Jettison Pushbutton.

Jettison Procedure

1. Click the Selective Jettison Knob until it is pointing at the CMBT position.
2. All weapons selection will be cleared and all stations (except Stations 1 and 7 if they are carrying Sidewinders) will be preselected.
3. Station selection is not possible in this mode.
4. Click on the Selective Jettison Pushbutton to initiate jettison.
5. Selective Jettison Knob returns to the OFF position when all selected stations have been jettisoned.

STORES

Jettison only selected stations. Automatic station selection based on weapon type. All stations can be selected. Suspension equipment is retained. AIM-9s on Station 1 and Station 7 are retained.

Interlocks

Landing Gear UP **AND** Aircraft is airborne (Weight Off Wheels).

Jettison Control

Selective Jettison Knob, Station Select Buttons and Selective Jettison Pushbutton.

Jettison Procedure

1. Click the Selective Jettison Knob until it is pointing at the STOR position.
2. All weapons selection will be cleared.
3. Select the station you want to jettison by clicking on its Station Select Button. All stations that carry the same weapon type will be selected/deselected.
4. Click on the Selective Jettison Pushbutton to initiate jettison.
5. Selective Jettison Knob returns to the OFF position when all selected stations have been jettisoned.

STATION

Jettison selected stations, including the suspension equipment. AIM-9s on Station 1 and Station 7 are retained.

Interlocks

Landing Gear UP **AND** Aircraft is airborne (Weight Off Wheels).

Jettison Control

Selective Jettison Knob, Station Select Buttons and Selective Jettison Pushbutton.

Jettison Procedure

6. Click the Selective Jettison Knob until it is pointing at the STA position.
7. All weapons selection will be cleared.
8. Select the station you want to jettison by clicking on its Station Select Button.
9. Click on the Selective Jettison Pushbutton to initiate jettison.
10. Selective Jettison Knob returns to the OFF position when all selected stations have been jettisoned.

NOTE

DCS does not allow the jettison of special pods like the LITENING II. Be prepared for Asymmetrical flying. ED will solve this problem in the future, at which time special pod jettison will be available.

ELECTRONIC WARFARE

Radar Warning Receiver (RWR)

The AV-8B comes equipped with the AN/ALR-67 (V)2 Radar Warning Receiver. The ALR-67 consists of electronic boxes located in the Avionics Bay in the aircraft tail, four sensors (one on each wing and two on the tail) that provide 360° coverage and a control panel to the right of the RIGHT MPCD in the Main Instruments Panel (see illustration in the COCKPIT Section).

There is no dedicated RWR display. Instead the RWR display can be selected on either MPCD by clicking on the ECM button (PB15) when the option is available.

NOTE

ECM option is available on all MPCD pages, except the TPOD page.

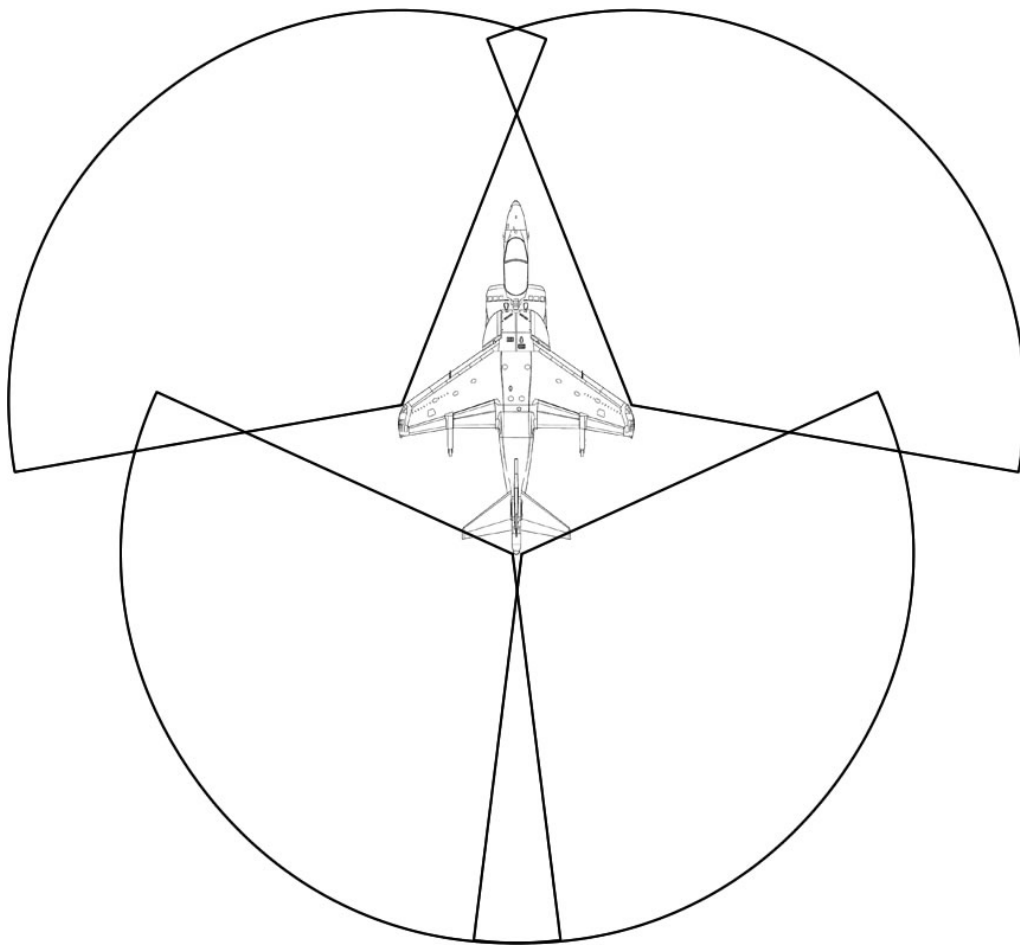

RWR Sensor coverage

RWR Display

The RWR display consists of 4 concentric circles at predetermined intervals. The circles do not represent range but signal strength and priority. High Priority signals, like radar locks or launch warnings, will be placed closer to the center. Low priority signals will be placed further from the center.

Each detected signal displayed consists of two parts: an alphanumeric code that identifies signal type, and a symbol that indicates emitter platform and priority.

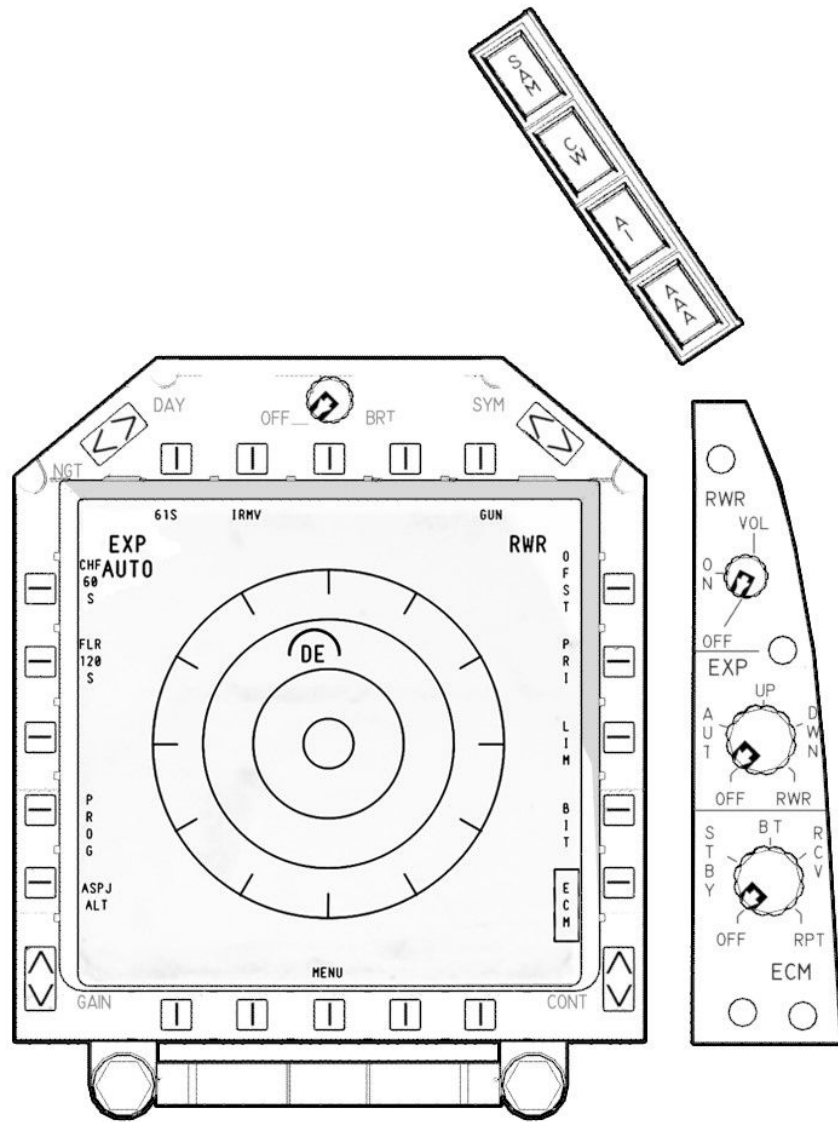

RWR Display on the RIGHT MPCD, Control Panel and Threat Lights

Missile Launch Warning System (MLWS)

The AV-8B NA does not have a Missile Launch Warning System.

Counter Measures Dispensers (CMD)

The AV-8B Night Attack has six dispensers, two below and four on top of the aft fuselage, that provide the aircraft with the capability to carry and dispense 180 expendables.

The available expendable types are:

1. Chaff: A metallic strip that provides a false radar reading for a short period of time.
2. Flares: a high temperature flare used to mask the engine heat signature.
3. Jammers: small radio devices used to confuse enemy radar receivers.

NOTE

DCS does not have an expendable jammer. The option is available only for realism purposes. Expendable jammers cannot be used.

Expendables loading.

Each dispenser module carries 30 units of the selected expendable type. The composition and number of expendables to be carried is tailored to the mission to be flown.

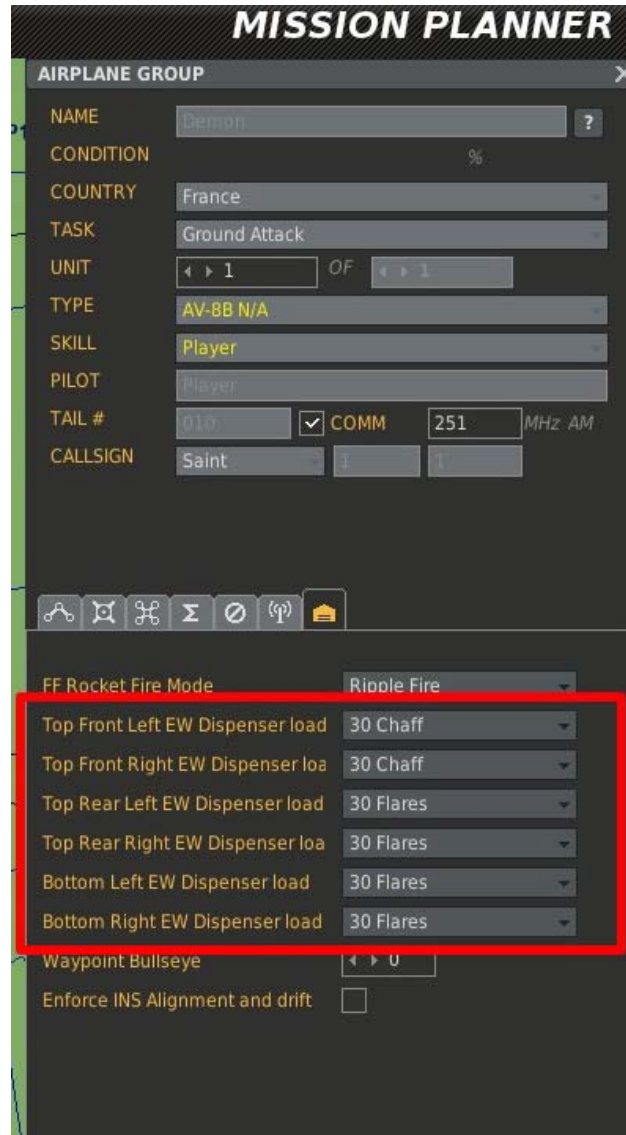

Expendable load screen

To load the expendables, DO NOT USE the Mission Editor Chaff and Flare controls. Instead go to the flight options panel and select the load for each dispensing module.

NOTE

Default expendables loadout is: 120 Flares and 60 Chaff, distributed as follows: 60 Chaff on the 1st. row of top dispensers, 60 flares on the 2nd. Row of top dispensers and 60 flares on the bottom dispensers.

Expendables dispensing programming.

This option is not available on initial Early Access release. It will be enabled in subsequent updates.

Expendables operation.

Expendables selected are controlled via the EXP switch on the ECM control panel (please refer to the instruments panel description). The EXP switch is a five-position switch with the following options:

1. OFF: Power is removed from the system. No expendable can be dispensed.
2. AUT: The system selects the dispenser based on aircraft altitude and velocity vector.
3. UP: The dispensers on top of the aft fuselage will be used first. Only after they are empty, the lower dispensers will be used.
4. DWN: The dispensers on the bottom aft fuselage will be used first. Only after they are empty, the top dispensers will be used.
5. RWR: Option not available.

NOTE

On UP and DWN modes, if the selected expendable is not available on the priority dispenser, the lower priority dispensers will be used.

Dispensing

Actual expendable dispensing is controlled via HOTAS buttons.

[ECM Dispense FWD: Flares]: Initiates dispensing of flares as programmed.

[ECM Dispense AFT: Chaff]: Initiates dispensing of chaff as programmed.

[ECM Dispense Left: Mini Jammer]: Initiates dispensing of jammers programmed. NOT OPERATIONAL.

[ECM Dispense Right: All]: Initiates dispensing of ALL expendables (chaff, flares and jammers) as programmed

Flare Salvo

Clicking on the FLR SAL button on the armament master switch panel initiates continuous flare dispensing. This button overrides operational mode selection. All flare containing dispensers are used. The release of flares will continue for as long as the FLR SAL button remains pressed.

Chaff and Jammers cannot be dispensed while the FLR SAL button is pressed.

AN/ALQ-164 RF JAMMER POD (DECM)

Description

The AN/ALQ-164 RF Jammer Pod (DECM) is an external pod mounted, active deception jammer. The DECM uses the ALQ-126B Charger Blue to counter pulse threats and the ALQ-162 Compass Sail to counter CW threats.

The ALQ-126B Charger Blue provides deceptive jamming against pulse-doppler threats in the E-J bands (2-18 GHz range) with a total output of approximately 1kW/band in a 60 degree beam width. AN/ALQ-126B modes include main lobe blanking, inverse con-scan, range-gate pull-off and swept square wave which make it particularly potent against established Soviet conically scanning systems such as the SA-6/Straight Flush tracking/illuminating radar or the ZSU-23-4P/Gun Dish fire control radar.

Because the ALQ-126B has no capability against CW threats, the AN/ALQ-164 pairs it with the ALQ-162 Compass Sail to counter pulse-doppler and continuous wave (CW) threats in the H-J bands (6-20 GHz range) in a 120 degree beam width. It can be operated autonomously or integrated with a radar warning receiver.

Characteristics

Type: Sensor Pod (RF Jammer)

Length: 215.9 cm (85 in.)

Diameter: 40.64 cm (16 in.)

Weight: 143.79 Kg (317 lbs)

STRS Code: DECM.

Installation: Center line pylon (Station 4).



DECM Operation.

AN/AAQ-28 LITENING II TARGETING POD (TPOD)

Description

The AN/AAQ-28 Litening II Targeting Pod (TPOD) is a multi-sensor targeting system developed to provide the AV-8B Night Attack with precision strike capability against surface targets. The TPOD is equipped with a Charged Coupled Device (CCD) TV and FLIR thermal imager to generate video on either MPCD.

Target designation is achieved by using a laser designator/range finder or an IR laser marker. The TPOD also includes a laser spot tracker capable of detecting and tracking laser energy.

Characteristics

Type: Sensor Pod (Targeting Pod)

Length: 220.98 cm (87 in.)

Diameter: 40.64 cm (16 in.)

Weight: 201.84 Kg (445 lbs)

STRS Code: TPOD.

Installation: Center line pylon (Station 4), Station 3 and Station 5.



[TPOD Video Display.](#)

[TPOD Operation.](#)

[MPCD Pushbutton Controls.](#)

[HOTAS/TDC Controls](#)

TPOD Modes of Operation

Air-to-Ground (A/G) Mode

Navigation (NAV) Mode

Air-to-Air (A/A) Mode

VCR Display Page

TPOD Laser Operations

APPENDICES

Default AWLS Channel List

CHNL	Airport/Airbase	RWY	TACAN	GS
01	Kobuleti	07	67X	3.0
02	Vaziani	14-32	22X	3.0
03	Kutaisi-Kopitnari	08	44X	3.0
04	Senaki-Kohlki	09	31X	3.0
05	Batumi	13	16X	3.0
06	Tiblisi-Lochini	13R	N/A	3.0
07	Tiblisi-Lochini	31L	N/A	3.0
08	Mineralnye Vody	12	N/A	3.0
09	Mineralnye Vody	30	N/A	3.0
10	Malchik	24	N/A	3.0
11	Beslan	10	N/A	3.0
12	Sochi - Adler	06	N/A	3.0
13	Nellis AFB	21	12X	3.0
14	Creech AFB	8	87X	3.0
15	Groom Lake AFB	32	18X	3.0
16	Tonopah Test Range Airfield	32	77X	3.0
17	Tonopah Test Range Airfield	14	77X	3.0
18	McCarran International	25	116X	3.0
19				
20				

Default COM 1 Channel List

Default COM 2 Channel List

Aircraft Weapons Loads

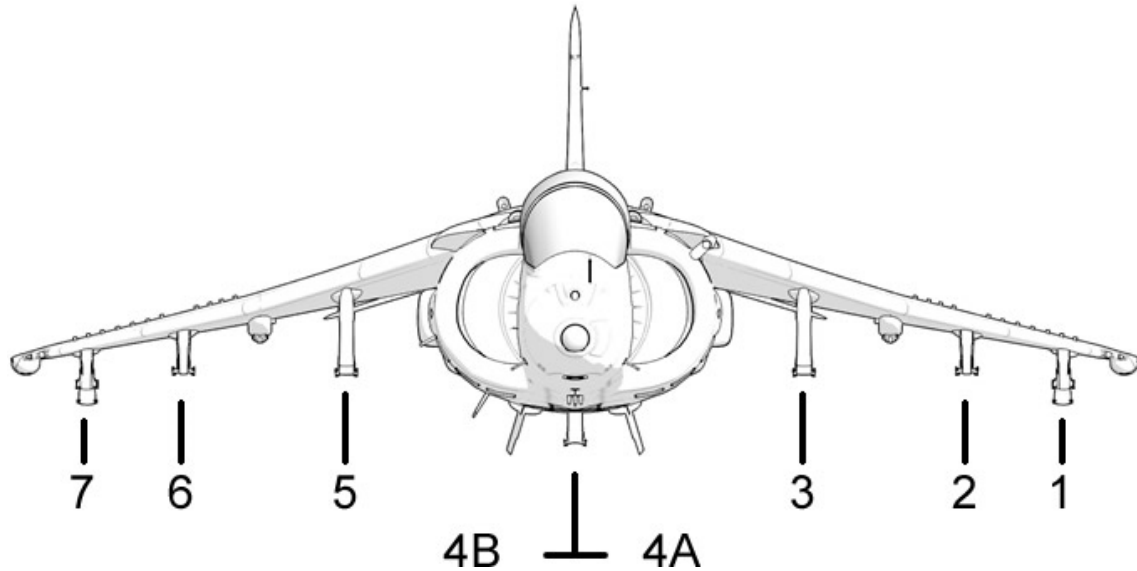

Authorized Weapons

Weapon	7	6	5	4B	4A	3	2	1
Air-To-Air								
AIM-9	1	1					1	1
Air-To-Ground								
MK-81 LD	1	3	3			3	3	1
MK-82 LD	1	3	3			3	3	1
MK-83 LD		1	3			3	1	
MK-20	1	2	3			3	2	1
GBU-12	1	3	3			3	3	1
GBU-16		1	3			3	1	
Mavericks		1	1			1	1	
LAU-10		2	3			3	2	
LAU-3		1	1			1	1	
LAU-68		2	1			1	2	
SUU-25		3	2			2	3	
MK-81SE (HD)	1	3	2			2	3	1
MK-82SE (HD)	1	3	2			2	3	1
GBU-38	1	3	2			2	3	1
AGM-122A	1	1					1	1
Pods								
GAU-12A					1			
AN/AAQ-28 Litening II			1	1		1		
AN/ALQ-164 DECM				1				
Fuel tanks		1	1			1	1	

Notes:

- Number represents maximum weapons load for the selected station.
- Aircraft can only load 2 different types of Air-to-Ground weapons. Any other weapon type will be ignored.

- AGM-122As are not considered Air-to-Ground weapons. Instead they are considered as an AIM-9 variant.
- Some of these loads will exceed maximum takeoff weight.
- Standard procedure when loading an AN/AAQ-28 into a wing station is to counter its weight with a GBU-12 on the opposite station. This bomb should not be used.
- Some weapons are not available on initial Early Access release.

Release Sequence

No. ITERS ABOARD	7	6	5	4B	4A	3	2	1
None	2	4	6			5	3	1
Two	2	4	6 8 10			5 7 9	3	1
Two	2	4 8 10	6			5	3 7 9	1
Four	2	6 8 13	4 10 11			3 7 14	5 9 12	1

Notes:

- Weapons are released in the sequence beneath the station number. The next weapon location in the sequence will be skipped if there is no selected weapon in that station.
- Release pulses are inhibited for Station 4A & Station 4B. Any unauthorized weapon loaded in those station will not be usable.

Default Loads

AFAC

Load Name	7	6	5	4B	4A	3	2	1
AFAC-1	AIM-9	SUU-25 x 3	LAU-68 x 3 WP	TPOD		LAU-68 x 3 WP	SUU-25 x 3	AIM-9
AFAC-2	AIM-9	SUU-25 x 3	LAU-68 x 3 WP		GAU-12	LAU-68 x 3 WP	SUU-25 x 3	AIM-9
AFAC-3	AGM-122	SUU-25 x 3	LAU-68 x 3 WP	DECM		LAU-68 x 3 WP	SUU-25 x 3	AIM-9

Anti-ship Strike

Load Name	7	6	5	4B	4A	3	2	1
AS-1	AGM-122	GBU-16	TPOD	DECM	GAU-12	GBU-12*	GUB-16	AIM-9
AS-2	AGM-122	AGM-65D	TPOD	DECM	GAU-12	GBU-12*	AGM-65D	AIM-9

* GBU-12 is loaded as counterweight for the TPOD.

CAS

Load Name	7	6	5	4B	4A	3	2	1
H-L-H 1	MK-82SE	MK-82SE	MK-82SE		GAU-12	MK-82SE	MK-82SE	MK-82SE
H-L-H 2		MK-82SE x 3	MK-82SE x 3		GAU-12	MK-82SE x 3	MK-82SE x 3	
H-M-H 1	MK-82	MK-82	MK-82		GAU-12	MK-82	MK-82	MK-82
H-M-H 2		MK-82SE x 3	MK-82SE x 2		GAU-12	MK-82SE x 2	MK-82SE x 3	
H-M-H 3	MK-82	MK-82SE x 2	TANK		GAU-12	TANK	MK-82SE x 2	MK-82
L-L-L	MK-82SE	MK-82SE	MK-82SE	DECM	GAU-12	MK-82SE	MK-82SE	MK-82SE
H-L-H 1	MK-82SE	MK-82SE	MK-82SE		GAU-12	MK-82SE	MK-82SE	MK-82SE

Escort

Load Name	7	6	5	4B	4A	3	2	1
Helo Escort 1	AIM-9	AIM-9		DECM	GAU-12		AIM-9	AIM-9
Helo Escort 2	AIM-9	AIM-9	TANK	DECM	GAU-12	TANK	AIM-9	AIM-9

Ground Attack

Load Name	7	6	5	4B	4A	3	2	1
Interdiction 1 (H-H-H-H)	AIM-9	MK-83	MK-83 x 2	DECM	GAU-12	MK-83 x 2	MK-83	AIM-9
Interdiction 2 (H-H-H-H)	AIM-9	TANK	MK-83 x 2	DECM	GAU-12	MK-83 x 2	TANK	AIM-9
Interdiction 3 (H-L-L-H)	AIM-9	MK-82SE	MK-82SE	DECM	GAU-12	MK-82SE	MK-82SE	AIM-9

Pinpoint Strike

Load Name	7	6	5	4B	4A	3	2	1
PGM 1 (1)(2) (H-H-H-H)	AIM-9	GBU-12 X 3	TPOD	DECM	GAU-12	GBU-12*	GBU-12 X 3	AIM-9
PGM 2 (1)(3) (H-H-H-H)	AIM-9	TANK	GBU-12 X 3	DECM	GAU-12	GBU-12 X 3	TANK	AIM-9
PGM 3 (1) (H-H-H-H)	AIM-9	GBU-16	GBU-16	TPOD	GAU-12	GBU-16	GBU-16	AIM-9
Anti-Armor	AIM-9	AGM-65G	AGM-65F		GAU-12	AGM-65G	AGM-65G	AIM-9

Notes:

1. For all PGM profiles, fuel load is 80% of total capacity.
2. GBU-12 on station 3 is loaded as counterweight for the TPOD.
3. Requires buddy lasing.

Runway Attack

Load Name	7	6	5	4B	4A	3	2	1
RA-1 (H-H-H-H)	AGM-122	MK-83	MK-83 x 2	DECM	GAU-12	MK-83 x 2	MK-83	AIM-9

SEAD

Load Name	7	6	5	4B	4A	3	2	1
Stand-Off 1	AGM-122	AGM-65G	AGM-65G	DECM	GAU-12	AGM-65G	AGM-65G	AIM-9
Stand-Off 2	AGM-122	AGM-122	AGM-65G	DECM	GAU-12	AGM-65G	AGM-122	AIM-9
Stand-Off 3	AIM-9	AGM-122	AGM-65G	DECM	GAU-12	AGM-65G	AGM-122	AIM-9
Close	AGM-122	AGM-122	LAU-3 HE	DECM	GAU-12	LAU-3 HE	AGM-122	AIM-9

Notes:

- All default loads assume 100% fuel, except where indicated.
- Default Chaff/Flare load (120 Flares, 60 Chaff) is assumed.
- 500 pounds of water is assumed.
- GBU-12s loaded as TPOD counterweight should not be used.
- Check total gross weight before attempting a Vertical Take Off.
- Do not attempt any landing with a full weapons load.

Glossary

AGL	Above Ground Level.
MSL	Mean Sea Level
H	High Altitude: refers to the best calculated altitude for maximum range or loiter time. Usually above 20,000 feet MSL.
M	Medium Altitude: About 10,000 feet MSL.
L	Low Altitude: 3,000 feet MSL or less. Minimum safe altitude is 500 feet AGL.
H-L-H	High-Low-High attack profile: After take-off, the aircraft will cruise to the target at high altitude. The attack run will be made at low altitude. The return trip will be made at high altitude.
H-M-H	High-Medium-High attack profile: After take-off, the aircraft will cruise to the target at high altitude. The attack run will be made at medium altitude. The return trip will be made at high altitude.
H-H-H	High-High-High attack profile: The aircraft will remain at high altitude always
L-L-L	Low-Low-Low attack profile: The aircraft will remain at low altitude always.
H-L-L-H	Variation of the H-L-H attack profile
H-H-H-H	Variation of the H-H-H attack profile.

Default Keyboard Binds

Category: Master Modes

Command	Key
Master Mode AG	"LAlt - 3"
Master Mode NAV	"LAlt - 1"
Master Mode VSTOL	"LAlt - 2"

Category: HUD Control

Command	Key
HUD Altimeter Selector	"LCtrl - LWin - Num4"
HUD Brightness Decrease - Off	
HUD Display Mode	"LCtrl - LWin - Num3"
HUD On - Brightness Increase	
HUD Reject Mode Down (NORM - REJ1 - REJ2)	"LCtrl - LWin - Num1"
HUD Reject Mode Up (REJ2 - REJ1 - NORM)	"LCtrl - LWin - Num2"

Category: VSTOL Controls

Command	Key
Flaps Mode Down (CRUISE - AUTO - STOL)	"LCtrl - 2"
Flaps Mode Up (STOL - AUTO - CRUISE)	"LCtrl - 1"
Flaps Power Left (OFF - ON - RESET)	"LCtrl - 3"
Flaps Power Right (RESET - ON - OFF)	"LCtrl - 4"
Water Mode Down (TO - OFF - LDG)	"LCtrl - 6"
Water Mode Up (LDG - OFF - TO)	"LCtrl - 5"

Category: Stability Augmentation & Autopilot

Command	Key
Automatic Flight Control On/Off Toggle	"A"
Altitude Hold On/Off Toggle	"H"
Q Feel On/Off Toggle	"RWin - Q"
Stability Augmentation - Pitch	"RWin - P"
Stability Augmentation - Yaw	"RWin - Y"
Stability Augmentation - Roll	"RWin - R"

Category: Armament Control Panel

Command	Key
Armament Mode Control Down	
Armament Mode Control Up	
Emergency Jettison Pushbutton	
IR Cooling control	
Jettison Pushbutton	
Launch Flare Salvo	"LCtrl - F"
Manual Release Control Left	
Manual Release Control Right	

Command	Key
Master Arm Switch	"LCtrl - M"
Multiple Release Control Down	
Multiple Release Control Up	
Release Interval (100s) Control Down	
Release Interval (100s) Control Up	
Release Interval (10s) Control Down	
Release Interval (10s) Control Up	
Release Interval (1s) Control Down	
Release Interval (1s) Control Up	
Release Quantity (10s) Control Down	
Release Quantity (10s) Control Up	
Release Quantity (1s) Control Down	
Release Quantity (1s) Control Up	
Selective Jettison Selector Left	
Selective Jettison Selector Right	
Station 1 Pushbutton	
Station 2 Pushbutton	
Station 3 Pushbutton	
Station 4 Pushbutton	
Station 5 Pushbutton	
Station 6 Pushbutton	
Station 7 Pushbutton	
Weapons Fuze Control Down	
Weapons Fuze Control Up	

Category: HOTAS

Command	Key
A/A Mode AFT: Sidewinder (SEAM)	"LShift - D"
A/A Mode DOWN: Gun	"C"
A/A Mode FWD: Sidewinder (Boresight)	"D"
AG Target Undesignate / NWS / FOV Toggle	"RWin - N"
Airbrake OFF	"LCtrl - B"
Airbrake ON	"LShift - B"
Airbrake TOGGLE	"B"
Bomb Pickle: Release Bombs/Launch Rockets, Mavericks	"RAlt - Space"
Cage/Uncage	"LWin - C"
COMM AFT: Select COMM 2	"LCtrl - Num+"
COMM FWD: Select COMM 1	"LCtrl - Num-"
ECM Dispense AFT: Chaff	"8"
ECM Dispense FWD: Flares	"7"
ECM Dispense LEFT: Mini Jammer	"9"
ECM Dispense RIGHT: All	"0"
Emergency Flap Retraction	
Emergency SAAHS Disconnect	
Engine Air Start	

Command	Key
Sensor Select AFT: DMT: LST/TV	"LWin - J"
Sensor Select DOWN: HUD Scene Reject/TGP	"LWin - N"
Sensor Select FWD: INS, IRMV/EOMV	"LWin - U"
Sensor Select LEFT: MAP Center/Decenter	"LWin - H"
Sensor Select RIGHT: FLIR/HUD-BH/WH	"LWin - K"
TDC Action/No Action Toggle	
TDC Aft	"J"
TDC Down (Action Position)	"N"
TDC Forward	"U"
TDC Left	"H"
TDC Right	"K"
Throttle Cutoff	"RWin - T"
Trigger: Fire Gun/Launch Sidewinder, Sidearm	"Space"
Trim Bank LEFT	"RCtrl - Left"
Trim Bank RIGHT	"RCtrl - Right"
Trim Pitch DOWN	"RCtrl - Up"
Trim Pitch UP	"RCtrl - Down"
WP Increment	"RWin - W"

Category: Hydraulic & Mechanical

Command	Key
Canopy Open/Close	"LCtrl - C"
Landing Gear DOWN	"LShift - G"
Landing Gear TOGGLE	"G"
Landing Gear UP	"LCtrl - G"
Parking Brake OFF	
Parking Brake ON	
Wheel Brake LEFT	"LShift - W"
Wheel Brake RIGHT	"LAlt - W"
Wheel Brakes	"W"

Category: Left MPCD

Command	Key
Left MPCD ADJ Decrease	
Left MPCD ADJ Increase	
Left MPCD BRT Decrease	
Left MPCD BRT Increase	
Left MPCD CON Decrease	
Left MPCD CON Increase	
Left MPCD Day illumination	
Left MPCD Disable power	
Left MPCD DSP Decrease	
Left MPCD DSP Increase	
Left MPCD Export View ON/OFF	

Command	Key
Left MPCD Night illumination	
Left MPCD OSB 01	
Left MPCD OSB 02	
Left MPCD OSB 03	
Left MPCD OSB 04	
Left MPCD OSB 05	
Left MPCD OSB 06	
Left MPCD OSB 07	
Left MPCD OSB 08	
Left MPCD OSB 09	
Left MPCD OSB 10	
Left MPCD OSB 11	
Left MPCD OSB 12	
Left MPCD OSB 13	
Left MPCD OSB 14	
Left MPCD OSB 15	
Left MPCD OSB 16	
Left MPCD OSB 17	
Left MPCD OSB 18	
Left MPCD OSB 19	
Left MPCD OSB 20	
Left MPCD SYM Decrease	
Left MPCD SYM Increase	

Category: Right MPCD

Command	Key
Right MPCD ADJ Decrease	
Right MPCD ADJ Increase	
Right MPCD BRT Decrease	
Right MPCD BRT Increase	
Right MPCD CON Decrease	
Right MPCD CON Increase	
Right MPCD Day illumination	
Right MPCD Disable power	
Right MPCD DSP Decrease	
Right MPCD DSP Increase	
Right MPCD Export View ON/OFF	
Right MPCD Night illumination	
Right MPCD OSB 01	
Right MPCD OSB 02	
Right MPCD OSB 03	
Right MPCD OSB 04	
Right MPCD OSB 05	
Right MPCD OSB 06	
Right MPCD OSB 07	

Command	Key
Right MPCD OSB 08	
Right MPCD OSB 09	
Right MPCD OSB 10	
Right MPCD OSB 11	
Right MPCD OSB 12	
Right MPCD OSB 13	
Right MPCD OSB 14	
Right MPCD OSB 15	
Right MPCD OSB 16	
Right MPCD OSB 17	
Right MPCD OSB 18	
Right MPCD OSB 19	
Right MPCD OSB 20	
Right MPCD SYM Decrease	
Right MPCD SYM Increase	

Category: Up Front Control

Command	Key
ODU Option 1	
ODU Option 2	
ODU Option 3	
ODU Option 4	
ODU Option 5	
UFC - Button	
UFC . Button	
UFC 0 Button	
UFC 1 Button	
UFC 2/N Button	
UFC 3 Button	
UFC 4/W Button	
UFC 5 Button	
UFC 6/E Button	
UFC 7 Button	
UFC 8/S Button	
UFC 9 Button	
UFC Altimeter Function Button	
UFC AWLS Function Button	
UFC Clear Button	
UFC EMCON Toggle Button	
UFC Enter Button	
UFC I/P Button	
UFC IFF Function Button	
UFC ON/OFF Toggle Button	
UFC RDR Beacon Function Button	
UFC Save Button	

Command	Key
UFC TACAN Function Button	
UFC Target-Of-Opportunity Function Button	
UFC Timer Function Button	
UFC Weapons Function Button	
UFC Wpt Over Fly Function Button	

Category: Miscellaneous Controls

Command	Key
DMT On/Off Toggle	"RWin - D"
FLIR On/Off Toggle	"RWin - F"
INS Mode Left (NAV - ALIGN - OFF)	"RWin - ,"
INS Mode Right (OFF - ALIGN - NAV)	"RWin - ."
Mission Computer Mode Down (OVRD - AUTO - OFF)	
Mission Computer Mode Up (OFF - AUTO - OVRD)	

Category: Engine & Fuel

Command	Key
Air Refueling Probe Toggle IN/OUT	"LWin - A"
Engines START	"RShift - Home"
Engines STOP	"RShift - End"
Fuel Shutoff Lever lock release	"LWin - F"

Category: Exterior Lights

Command	Key
Air Refueling Probe Light Toggle	
Anti-Collision Lights Toggle	
Auxiliary (Taxi) Light Toggle	
Exterior Lights Master Switch NORM-NVG-OFF	
Exterior Lights Master Switch OFF-NVG-NORM	
Exterior Lights Toggle	
Formation Lights Knob Brightness Increase	
Formation Lights Knob Brightness Increase	
Landing Light Switch APP-HVR-OFF	
Landing Light Switch OFF-HVR-APP	
Position Lights Switch BRT-DIM-OFF	
Position Lights Switch OFF-DIM-BRT	

Category: Pilot & Seat Controls

Command	Key
Eject (3 times)	"LCtrl - E"
Hide/Show Control Stick	"RCtrl - RWin - S"
Hide/Show Pilot Body	"RCtrl - RWin - P"
Hide/Show Throttle	"RCtrl - RWin - T"
Mirrors TOGGLE	"LShift - M"

